



Midea Building Technologies Division

# ESG-Inv M Series Pool Heat Pump



# CONTENTS

<b>Part 1 General Information.....</b>	<b>3</b>
<b>Part 2 Engineering Data .....</b>	<b>5</b>
<b>Part 3 Component Layout and Refrigerant Circuits.....</b>	<b>17</b>
<b>Part 4 Control .....</b>	<b>21</b>
<b>Part 5 Diagnosis and Troubleshooting.....</b>	<b>27</b>
<b>Part 6 Parts Replacement .....</b>	<b>71</b>



# Part 1

# General Information

1 LINEUP .....	4
2 NOMENCLATURE .....	6

### 1 Lineup

Model	MSC-70D2N8-A	MSC-90D2N8-A	MSC-120D2N8-A
Appearance			
220-240V~ 50Hz	●	●	●

### 2 Nomenclature

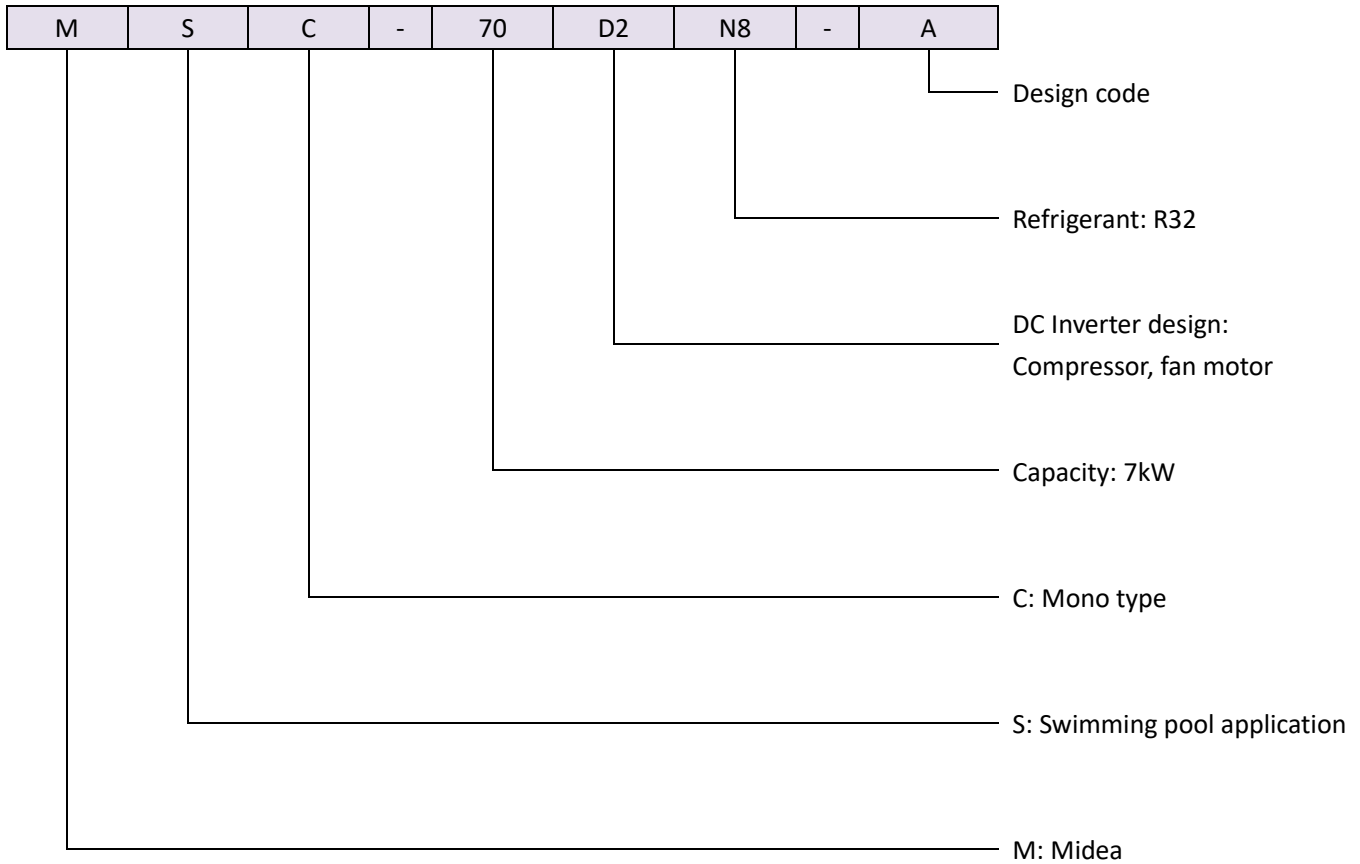

# Part 2

# Engineering Data

1 Specifications .....	6
2 Electrical characteristics .....	7
3 Dimensions and center of gravity .....	8
4 Operating limits.....	8
5 Heating performance .....	9
6 Hydronic performance.....	12
7 Octave band sound level .....	13

## 1 Specifications

MODEL			MSC-70D2N8-A	MSC-90D2N8-A	MSC-120D2N8-A
Power supply			220-240V~ 50Hz	220-240V~ 50Hz	220-240V~ 50Hz
Heating (A27/24.3°C, W28°C)	Capacity	kW	7.16	9.15	12.50
	Rated input	kW	0.95	1.35	1.79
	COP		7.50	6.80	7.00
Boost Heating (A27/24.3°C, W28°C)	Capacity	kW	10.30	12.80	14.50
	Rated input	kW	1.56	2.13	2.28
	COP		6.60	6.00	6.35
Heating (A15/12°C, W28°C)	Capacity	kW	5.30	6.80	9.12
	Rated input	kW	1.04	1.39	1.81
	COP		5.10	4.90	5.05
Boost Heating (A15/12°C, W28°C)	Capacity	kW	7.30	9.30	10.50
	Rated input	kW	1.56	2.09	2.28
	COP		4.69	4.45	4.60
Heating (A7/6°C, W28°C)	Capacity	kW	4.40	5.00	7.60
	Rated input	kW	1.05	1.28	1.77
	COP		4.20	3.90	4.30
Heating (A2/1°C, W28°C)	Capacity	kW	3.40	4.20	5.50
	Rated input	kW	0.94	1.22	1.53
	COP		3.60	3.45	3.60
Cooling (A35/-°C, W28°C)	Capacity	kW	4.50	5.20	7.00
	Rated input	kW	1.13	1.55	1.75
	EER		4.00	3.35	4.00
Cooling (A43/-°C, W28°C)	Capacity	kW	3.40	3.60	5.10
	Rated input	kW	1.31	1.44	1.59
	EER		2.60	2.50	3.20
Max. running input		W	2200	2600	2800
Max. running current		A	10.5	11.0	12.0
Compressor	Type		DC Rotary	DC Rotary	DC Rotary
	Oil type		ESTER OIL VG74	ESTER OIL VG74	ESTER OIL VG74
	Oil charged	ml	420	420	420
Outdoor fan	Motor type		DC Brushless	DC Brushless	DC Brushless
	Number of fans		1	1	1
	Air flow	m <sup>3</sup> /h	3200	3800	3900
Air side heat exchanger	Type		Finned tube	Finned tube	Finned tube
Refrigerant	Type		R32	R32	R32
	GWP		675	675	675
	Charged volume	kg	0.55	0.55	0.75
Throttle type			EXV	EXV	EXV
Water side heat exchanger		Material	Titanium	Titanium	Titanium
Water side connection	Type		Internal thread Glue connection	Internal thread Glue connection	Internal thread Glue connection
	mm		φ50	φ50	φ50
Water flow range		m <sup>3</sup> /h	3.1	3.9	5.4

Water pressure drop		kPa	4.6	7.3	13.8
Sound pressure Level	Heating (A27/24.3℃, W28℃)	dB(A)	41	43	49
	Heating max	dB(A)	48	52	55
	heating slince mode1	dB(A)	39	39	40
	heating slince mode2	dB(A)	38	38	38
	Cooling (A35/-℃, W28℃)	dB(A)	43	45	48
	Cooling max	dB(A)	43	45	48
	Cooling slince mode1	dB(A)	40	41	43
	Cooling slince mode2	dB(A)	39	40	40
Unit dimension (W×H×D)		mm	988×426×712	988×426×712	988×426×712
Packing dimension (W×H×D)		mm	1065×485×845	1065×485×845	1065×485×845
Net weight		kg	46	46	50
Gross weight		kg	53	53	57
Ambient temperature range	Cooling	℃	15~43	15~43	15~43
	Heating	℃	-7~43	-7~43	-7~43
Water inlet temperature setting range	Cooling	℃	12~30	12~30	12~30
	Heating	℃	10~40	10~40	10~40
Nominal outlet water temperature range	Cooling	℃	10~28	10~28	10~28
	Heating	℃	12~42	12~42	12~42

The above data test reference standard EN14511; EN50564:2011; 12102:2011; OJ 2014/C 207/02:2014

## 2 Electrical characteristics

Model	Outdoor unit				Power current			Compressor	Fan motor	
	Voltage (V)	Hz	Min. (V)	Max. (V)	MCA (A)	TOCA (A)	MFA (A)	RLA (A)	kW	FLA (A)
MSC-70D2N8-A	230	50	198	264	10.5	14.0	16.0	6.8	0.05	0.4
MSC-90D2N8-A	230	50	198	264	11.0	14.0	16.0	9.3	0.08	0.5
MSC-120D2N8-A	230	50	198	264	12.0	14.0	16.0	10.0	0.11	0.7

**Note:**

MCA: Min. circuit amps.(For wire diameter selection)

TOCA: Total over-current amps(For air-break switch selection)

MFA: Max. fuse amps(For fuse selection)

RLA: Rated load amps. The input amps of compressor where maximum Hz can operate for nominal cooling or heating test condition

kW: Rated motor output

FLA: Full load amps.



### 3 Dimensions and Center of Gravity

MSC-70D2N8-A  
 MSC-90D2N8-A  
 MSC-120D2N8-A  
 (Unit: mm)

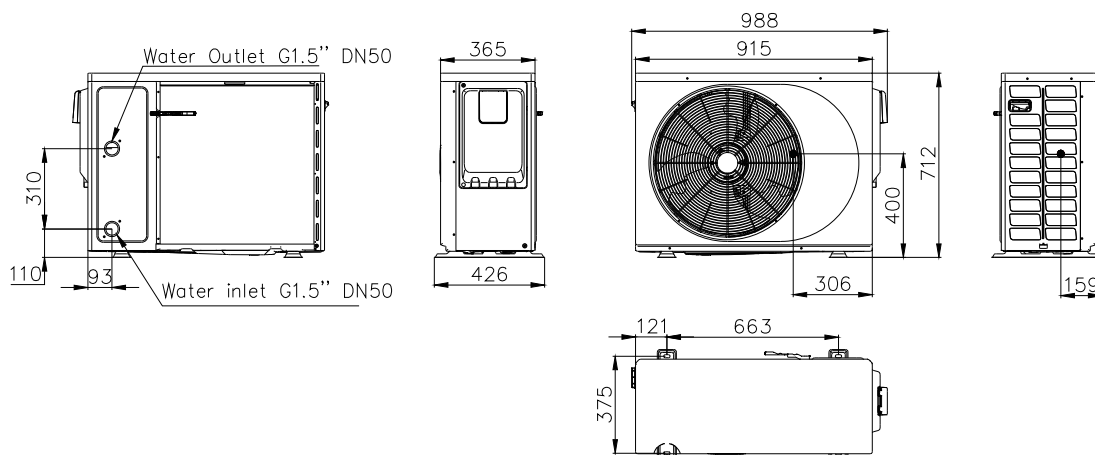

### 4 Operating limit

Heating

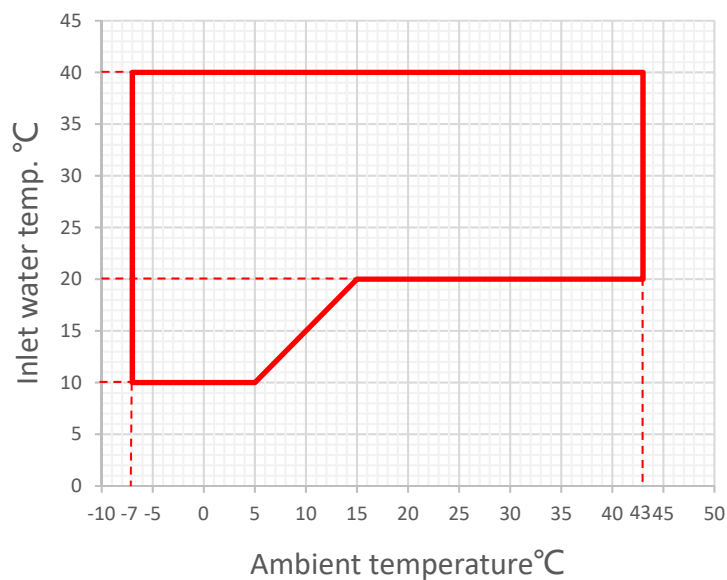

Cooling

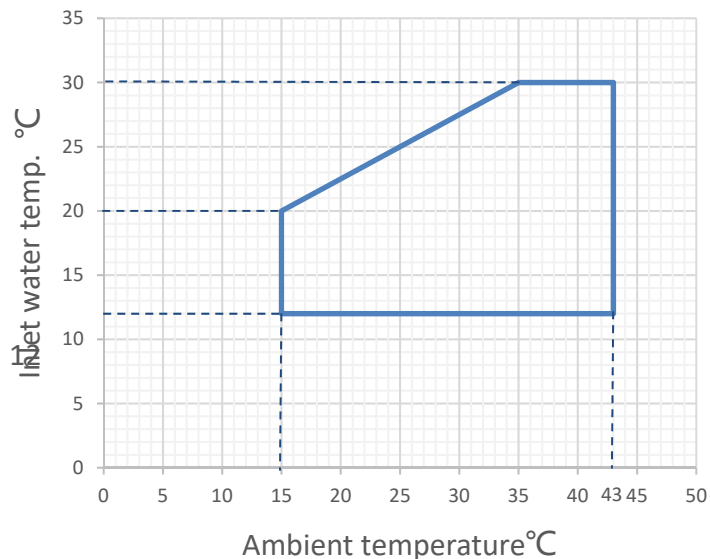

## 5 Heating performance

Normal heating, rating heating frequency, W 28°C

MSC-70D2N8-A

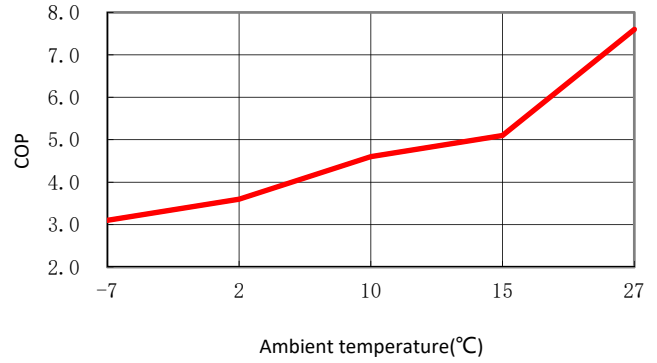
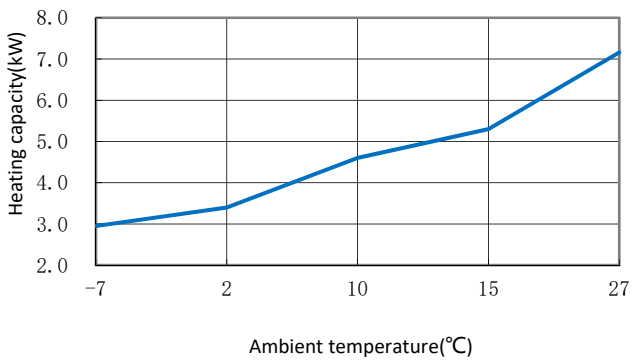

MSC-90D2N8-A

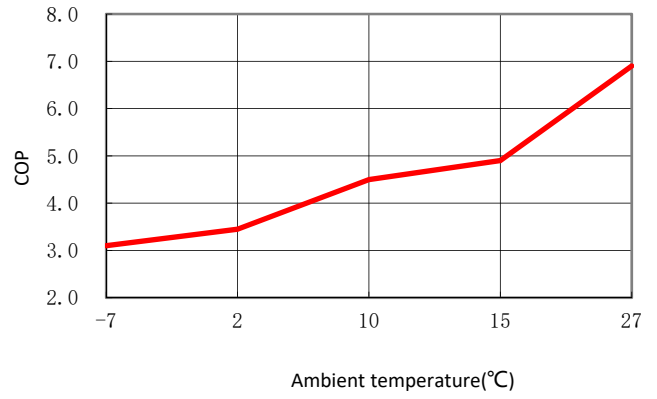
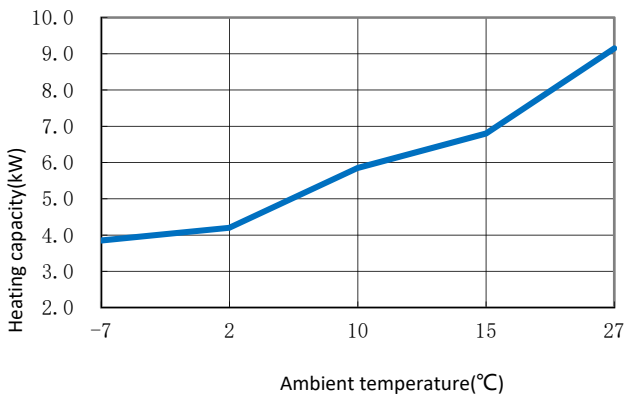

MSC-120D2N8-A

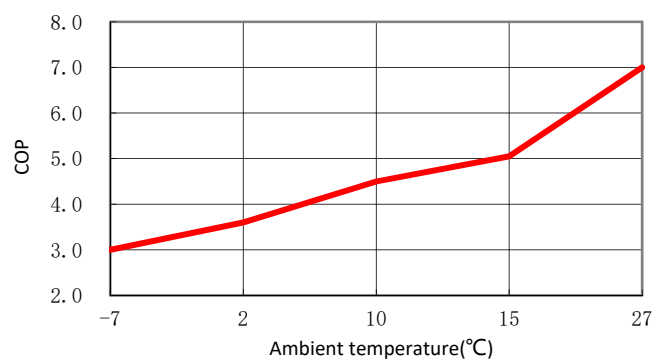
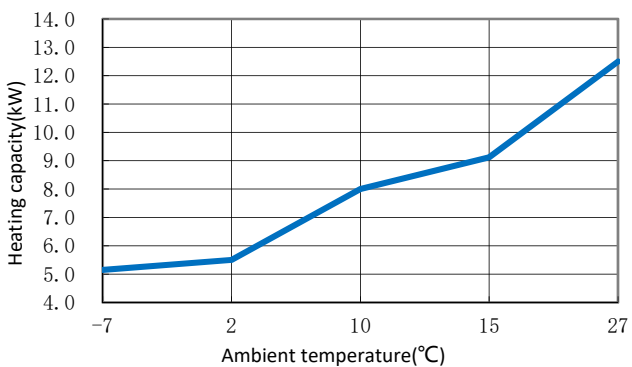

# ESG-Inv M



Normal heating, A27/24.3°C, W28°C

MSC-70D2N8-A

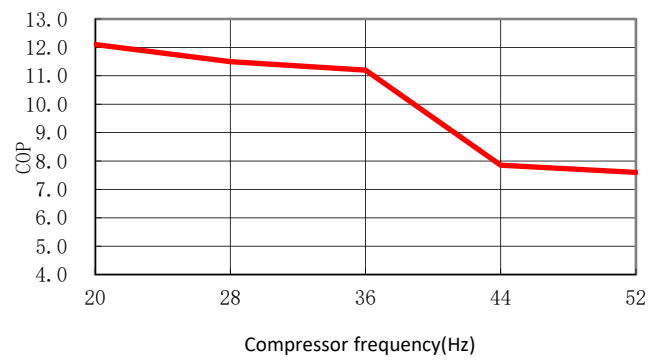
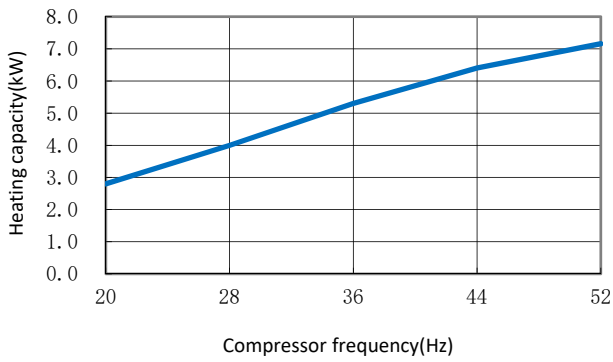

MSC-90D2N8-A

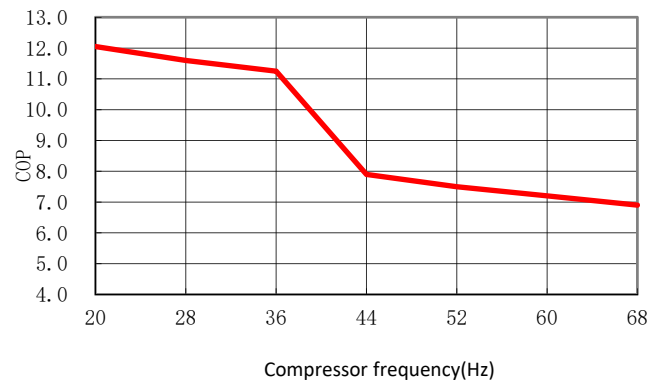
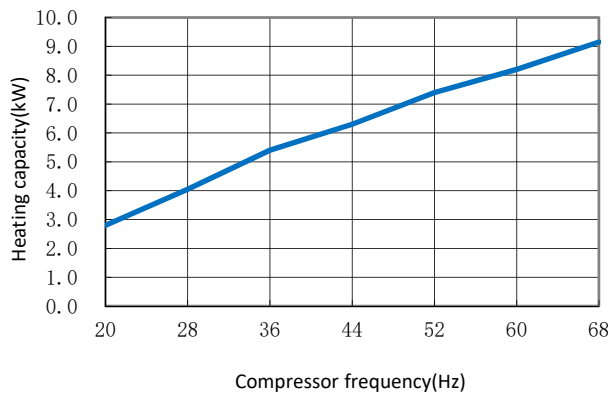

MSC-120D2N8-A

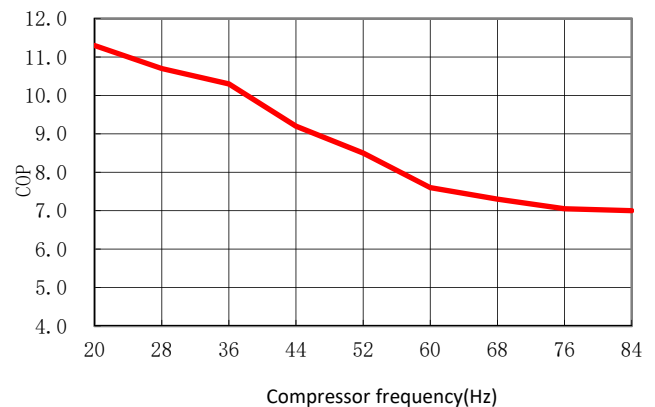
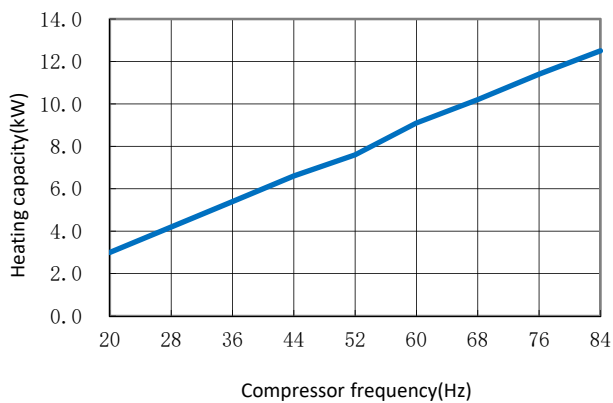

Normal heating, A15/12°C, W28°C

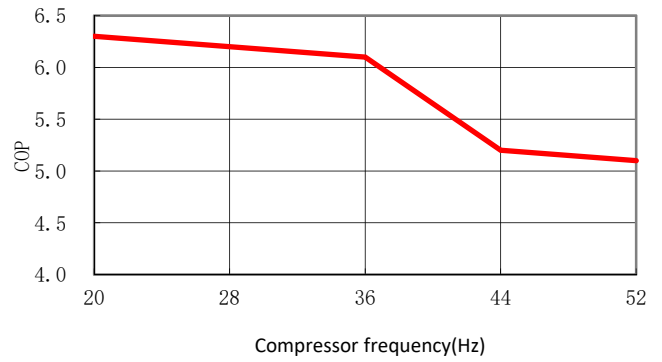
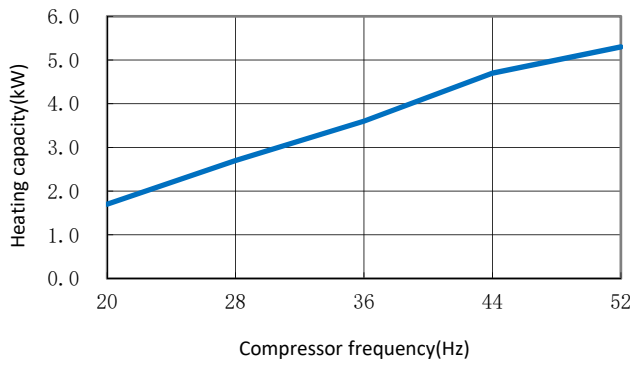
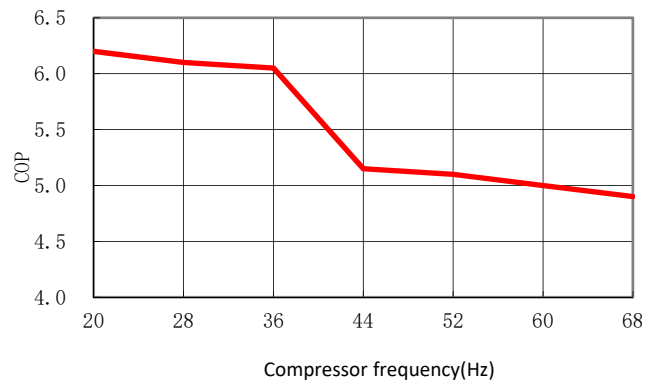
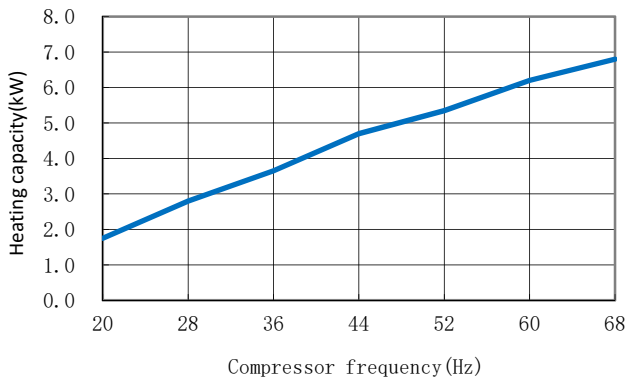
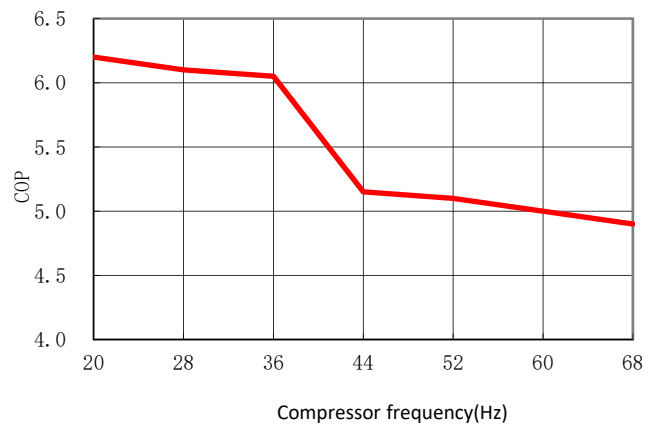
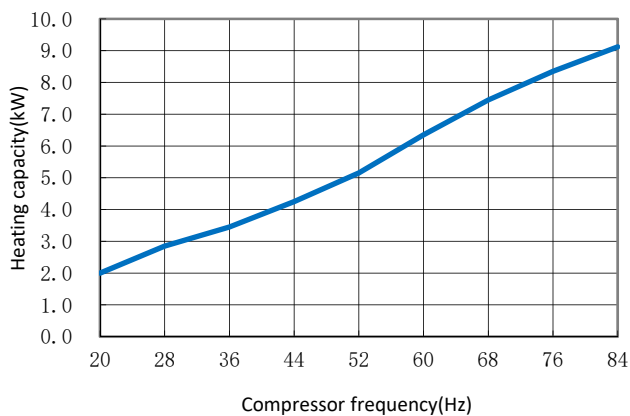
**MSC-70D2N8-A**

**MSC-90D2N8-A**

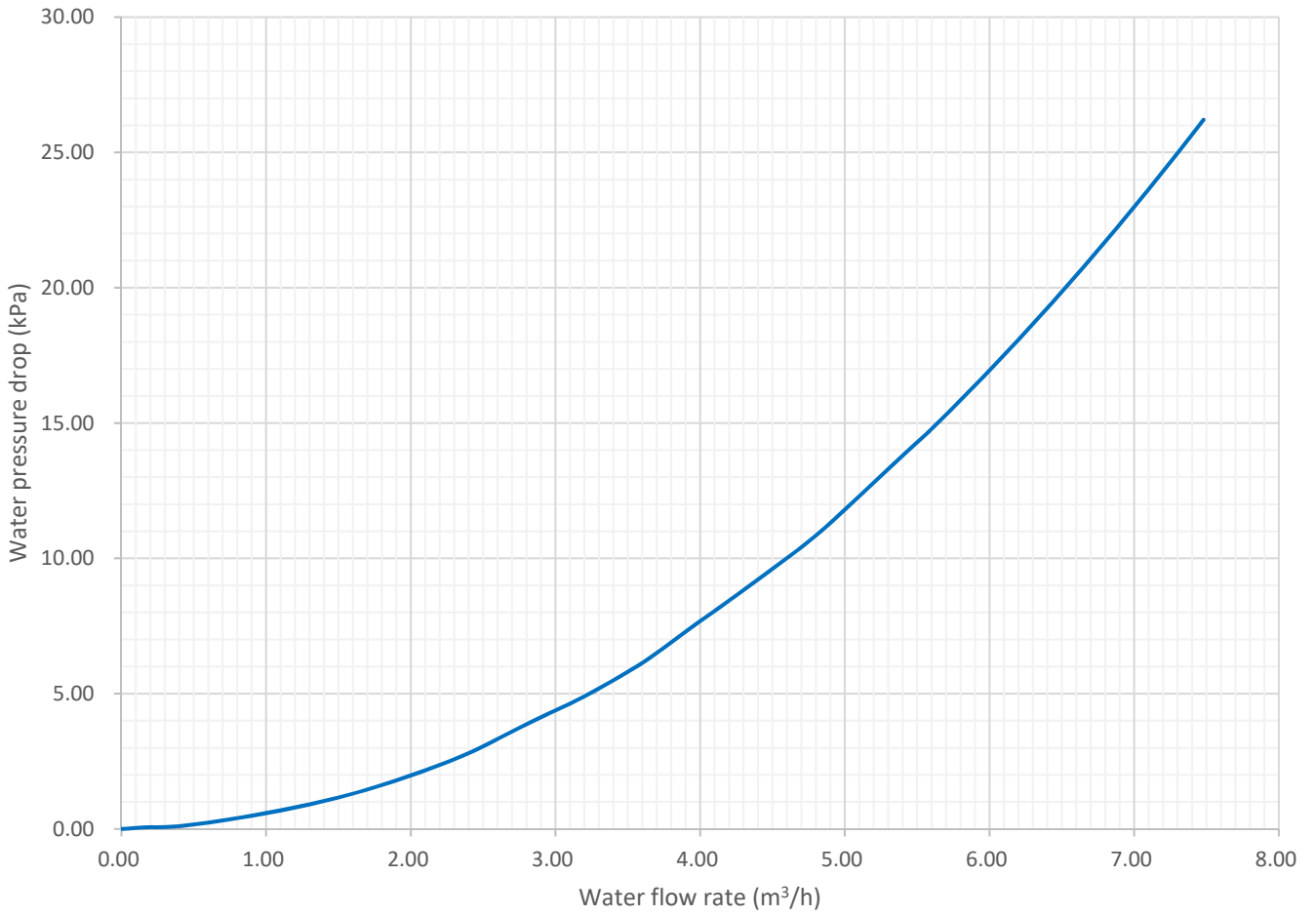
**MSC-120D2N8-A**

## 6 Hydronic performance

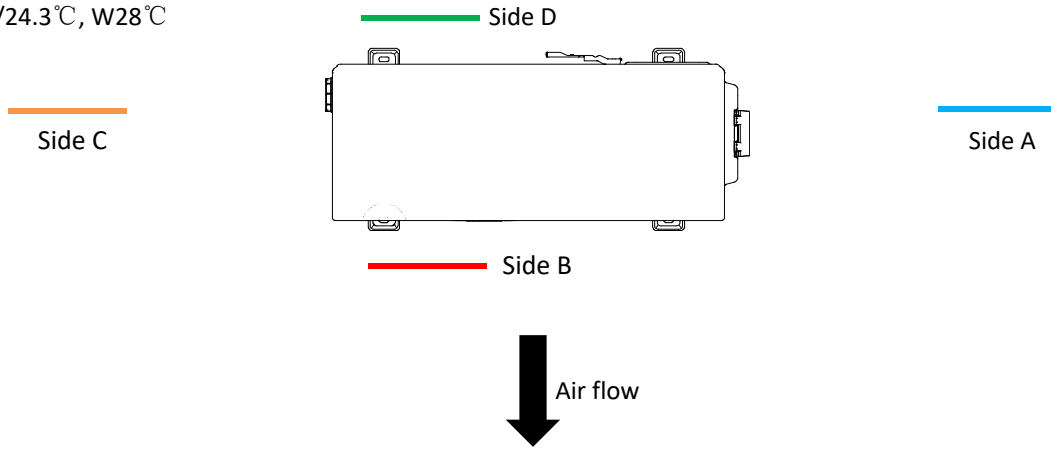

### 7 Octave band sound level

Heating: A27/24.3°C, W28°C



MSC-70D2N8-A

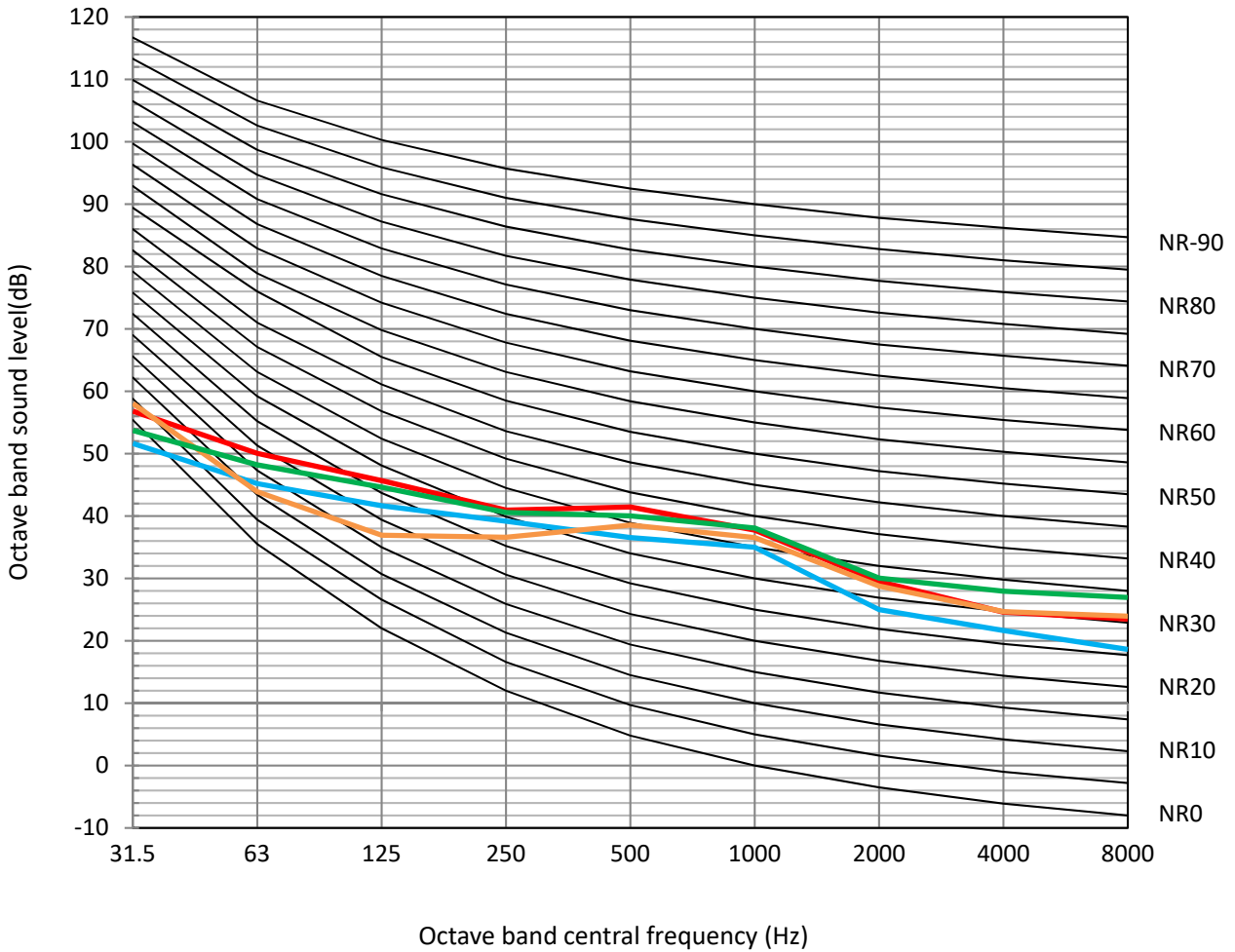

MSC-90D2N8-A

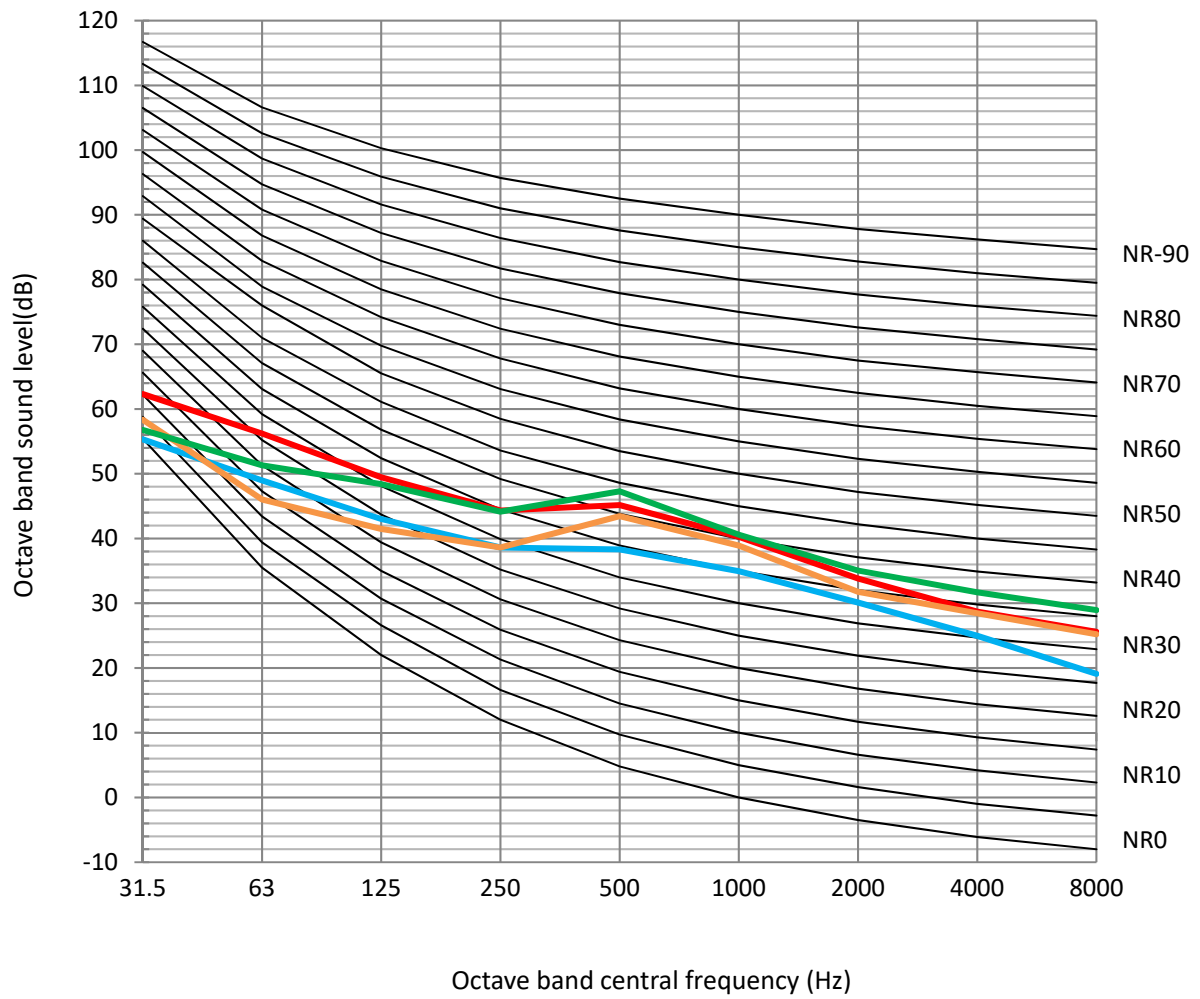

MSC-120D2N8-A

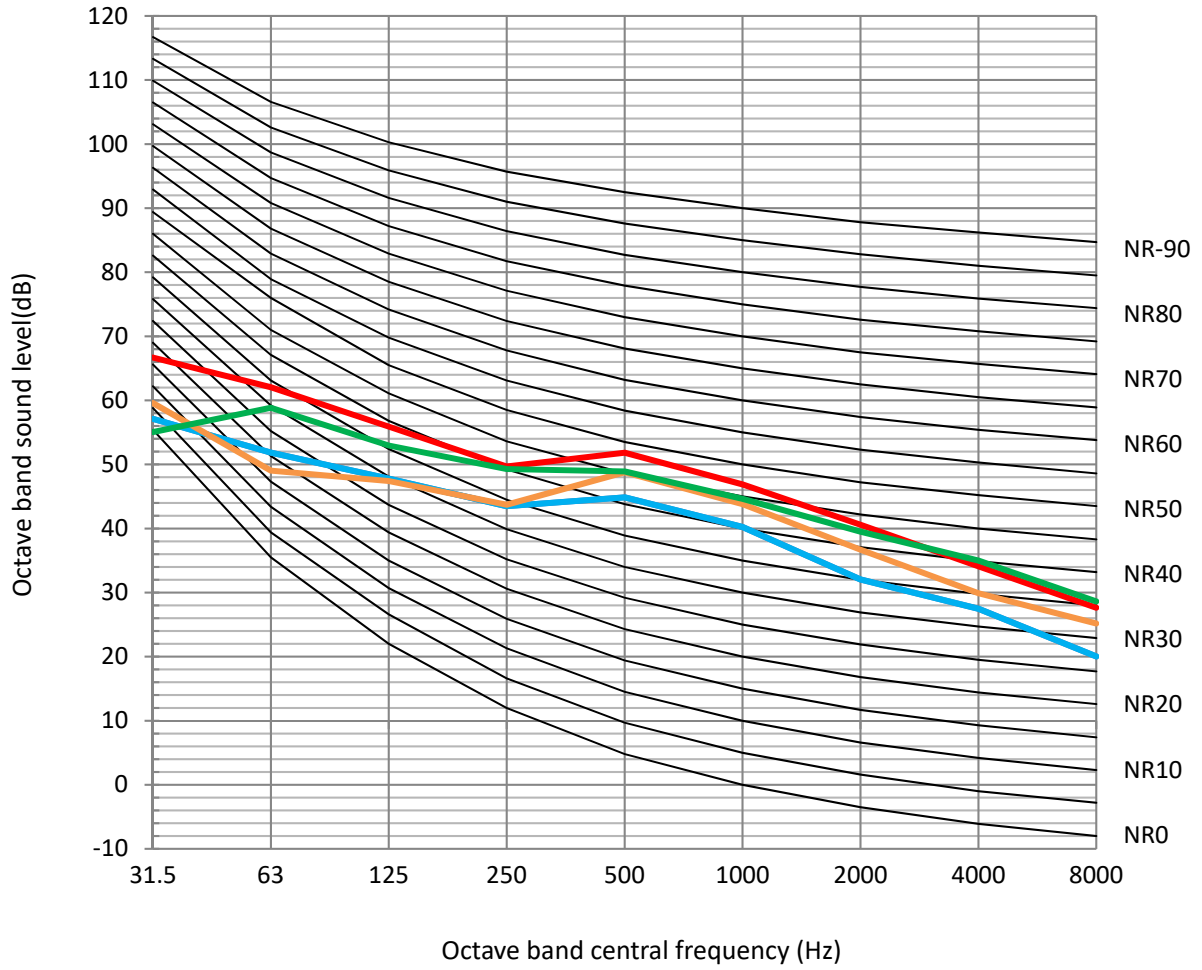





# Part 3

# Component Layout and Refrigerant Circuits

1 Layout of Functional Components.....	18
2 Piping Diagrams .....	19

# 1 Layout of Functional Components

MSC-70D2N8-A, MSC-90D2N8-A, MSC-120D2N8-A

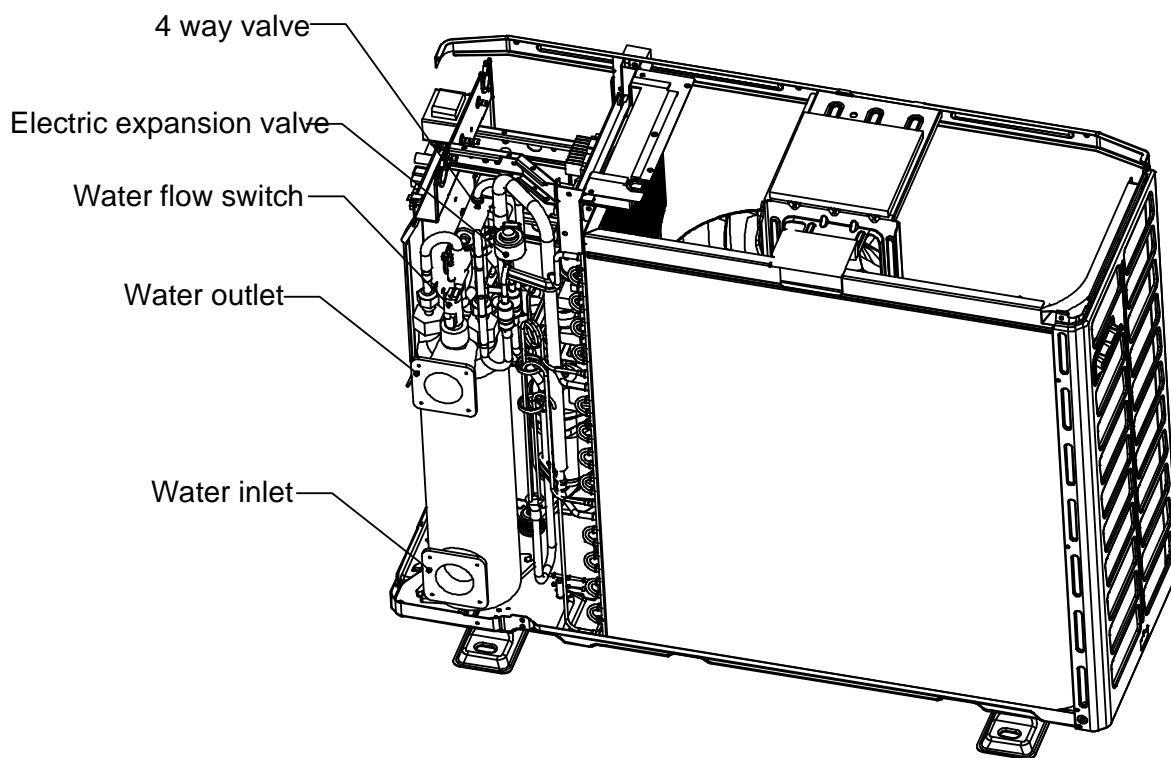
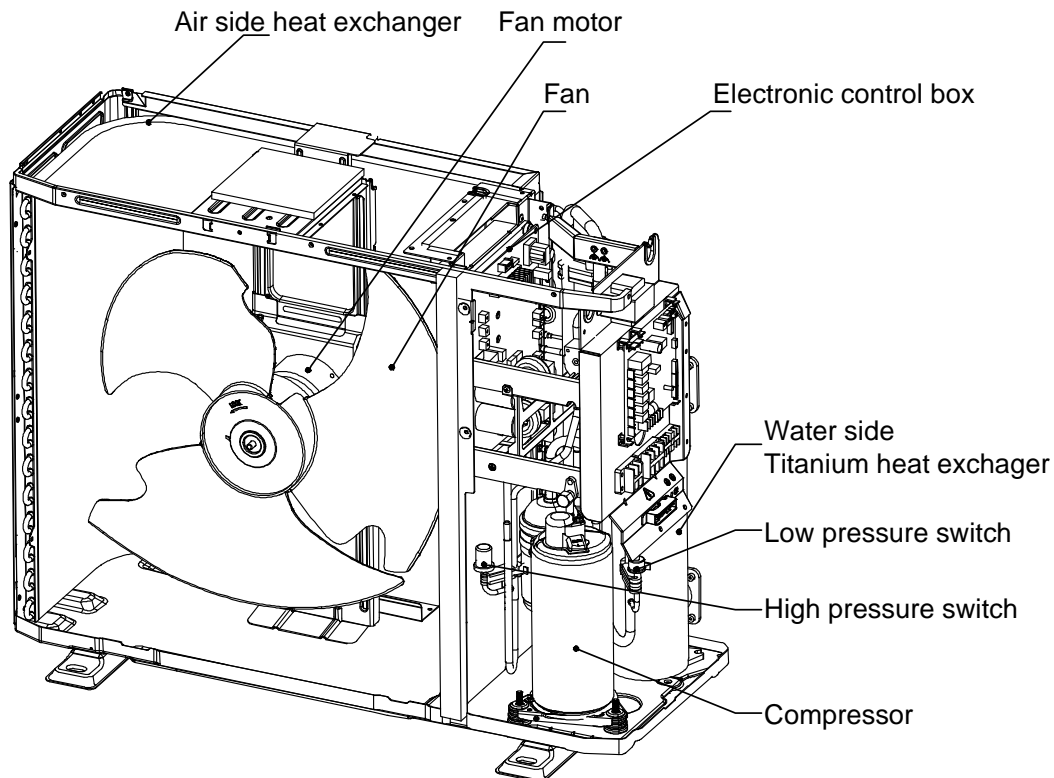

## 2 Piping Diagrams

Refrigerant piping graphic example:

- High temperature, high pressure gas
- High temperature, high pressure liquid
- Low temperature, low pressure gas liquid mixture
- Low temperature, low pressure gas

Heating mode

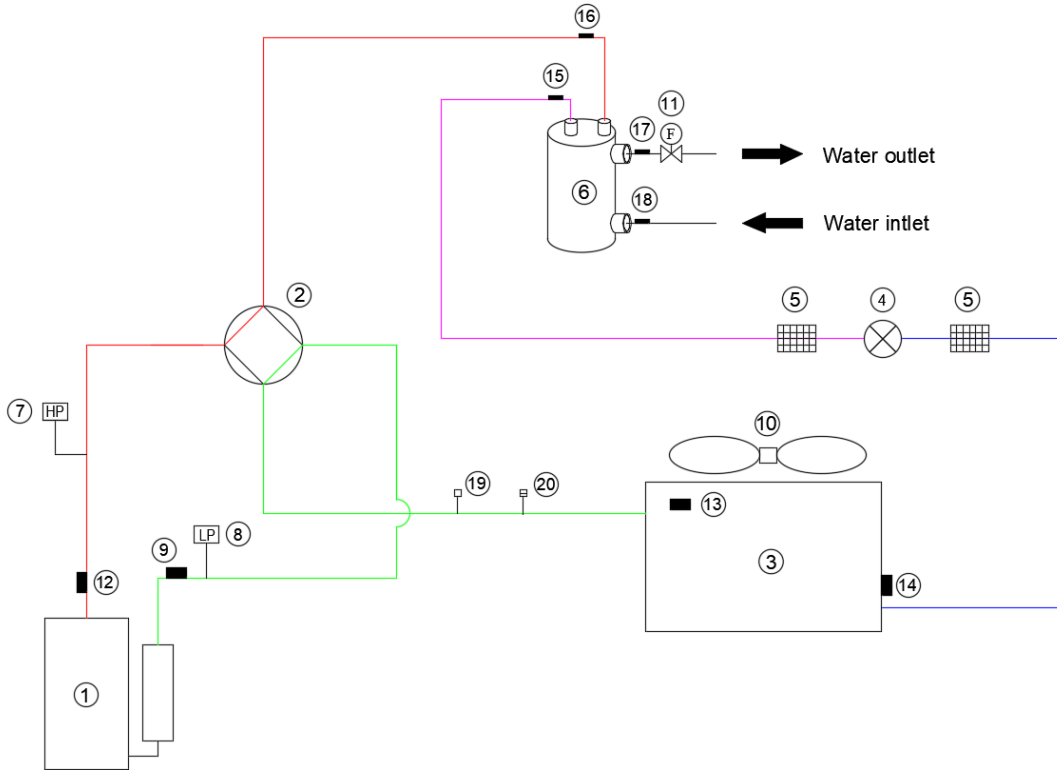

Cooling/Defrost mode

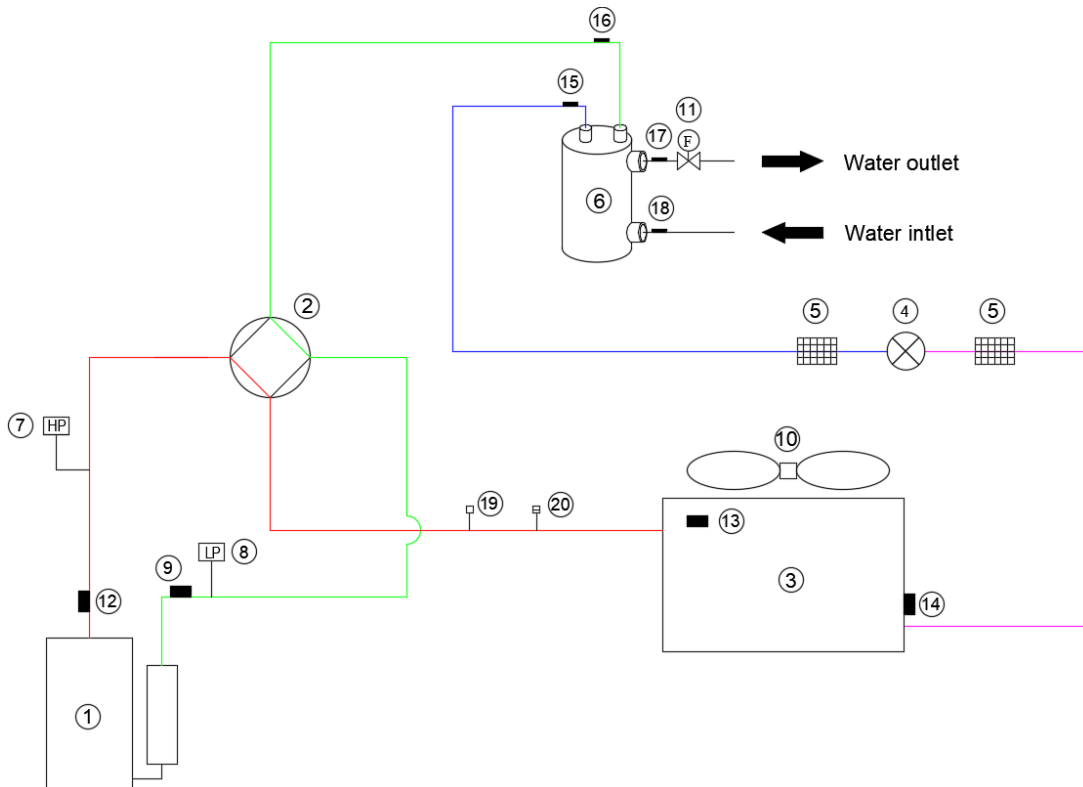

Legend			
1	Compressor	11	Water flow switch
2	4-way valve	12	Discharge temperature sensor(Tp)
3	Air side heat exchanger	13	Ambient temperature sensor(T4)
4	Electronic expansion valve	14	Evaporation temperature sensor in heating /Condenser temperature sensor in cooling(T3)
5	Strainer	15	Refrigerant inlet(liquid pipe) temperature sensor(T2)
6	Water side titanium heat exchanger	16	Refrigerant outlet(gas pipe) temperature sensor(T2B)
7	High pressure switch	17	Water outlet temperature sensor
8	Low pressure switch	18	Water inlet temperature sensor
9	Suction temperature sensor	19	Service port
10	DC fan	20	Lok ring

### Key components:

#### Compressor:

When the refrigerant gas passes through the compressor, refrigerant pressure increases and temperature rises above that of the water in the water system.

#### Electronic expansion valve (EXV):

Controls refrigerant flow and reduces refrigerant pressure.

#### Four-way valve:

The four-way valve is used to change the direction of refrigerant flow in order to switch between heating and cooling/defrosting operations. During the cooling/defrosting mode, 4-way valve is powered off, the air side heat exchanger functions as a condenser and titanium heat exchanger as an evaporator. For heating mode, 4-way valve is powered on, the air side heat exchanger functions as an evaporator and titanium heat exchanger as a condenser.

#### High/low pressure switch:

Regulate refrigerant system pressure. When refrigerant system pressure exceeds upper/lower limit, the high/low pressure switch turns off, stopping the compressor.

#### Fan assembly:

Forcing air convection to enhance the heat exchange performance.

#### Water flow switch:

Ensure the water flow is reasonable to enhance system reliability. If the water flow is insufficient, unit stops to protect the water side titanium heat exchanger from freezing crack in cooling mode and unit stops to avoid excessive high pressure or discharge temperature of the system in heating mode.

#### Strainer:

Filter out impurities to avoid electronic expansion valve stuck

#### Water side titanium heat exchanger:

Used for heat exchange between water and refrigerant

#### Air side heat exchanger:

Used for heat exchange between air and refrigerant

#### Service port:

Used for releasing refrigerant, adding refrigerant, connecting pressure meter

#### Lok ring

Used for sealing the refrigerant system in factory, which can not be used for aftersales service on site.

# Part 4

# Control

1 Stop .....	22
2 Standby .....	22
3 Startup operation .....	22
4 Normal operation .....	23
5 Special Control.....	24

## 1 Stop

The stop operation occurs for one of the following reasons:

- Abnormal shutdown: in order to protect the compressors, if an abnormal state occurs the system stops and an error code is displayed on the outdoor unit PCB digital displays and on the user interface.
- The system stops when the set temperature has been reached.

## 2 Standby

### 2.1 Water Pump Control

The water pump will run regularly to circulate the pool water to the heat pump so that the water temperature of the pool can be detected, and heat pump can provide hot/cold water in time.

## 3 Startup operation

### 3.1 Compressor

- Startup Delay

In initial startup control and in restart control (except in oil return operation and defrosting operation), compressor startup is delayed such that a minimum of the set re-start delay time 3minutes has elapsed since the compressor stopped, in order to prevent frequent compressor on/off and to equalize the pressure within the refrigerant system.

- Startup platform

In initial startup control and in re-start control, compressor startup is controlled according to outdoor ambient temperature. Compressor startup follows one of two startup programs until the target rotation speed is reached.

Cooling mode: Ambient temperature is above 12°C  Heating mode: Ambient temperature is above 0°C	Cooling mode: Ambient temperature is below 12°C  Heating mode: Ambient temperature is below 0°C for initial power on Or Ambient temperature is below 0°C after compressor stops for 4 hours
Compressor rotation speed(rps) 	Compressor rotation speed(rps) 

### 3.2 Heating

Component	Wiring diagram label	Control functions and states
Inverter compressor	COMP	Compressor startup program selected according to ambient temperature
DC fan motor	FAN	Fan run at maximum speed
Electronic expansion valve	EXV	Position (steps) from 0 (fully closed) to 480 (fully open), controlled according to outdoor ambient temperature, discharge temperature, suction superheat, compressor speed and refrigerant system pressure
Four-way valve	4-WAY	On

### 3.3 Cooling

Component	Wiring diagram label	Control functions and states
Inverter compressor	COMP	Compressor startup program selected according to ambient temperature
DC fan motor	FAN	Fan run at maximum speed
Electronic expansion valve	EXV	Position (steps) from 0 (fully closed) to 480 (fully open), controlled according to outdoor ambient temperature, discharge temperature, suction superheat, compressor speed and refrigerant system pressure
Four-way valve	4-WAY	Off

## 4 Normal operation

### 4.1 Heating

Component	Wiring diagram label	Control functions and states
Inverter compressor	COMP	Controlled according to load requirement from temperature set and outlet water temperature
DC fan motor	FAN	Controlled according to outdoor heat exchanger pipe temperature
Electronic expansion valve	EXV	Position (steps) from 0 (fully closed) to 480 (fully open), controlled according to outdoor ambient temperature, discharge temperature, suction superheat, compressor speed , refrigerant system pressure and temperature
Four-way valve	4-WAY	On

### 4.2 Cooling

Component	Wiring diagram label	Control functions and states
Inverter compressor	COMP	Controlled according to load requirement from set temperature and outlet water temperature
DC fan motor	FAN	Controlled according to outdoor heat exchanger pipe temperature
Electronic expansion valve	EXV	Position (steps) from 0 (fully closed) to 480 (fully open), controlled according to outdoor ambient temperature, discharge temperature, suction superheat, compressor speed and refrigerant system pressure
Four-way valve	4-WAY	Off

### 4.3 Component

- Compressor

The compressor rotation speed is controlled according to the load requirement. Before compressor startup, heat pump determines the compressor target speed according to outdoor ambient temperature, inlet water set temperature and actual inlet water temperature and then runs the appropriate compressor startup program. Once the startup program is completed, the compressor runs at the target rotation speed. During operation the compressor speed is controlled according to the rate of change in water temperature, the refrigerant system pressure and the refrigerant temperature. The running speed of six-pole compressors in rotations per second (rps) is one third of the frequency (in Hz) of the electrical input to the compressor motor. The frequency of the electrical input to the compressor motors can be altered at a rate of 1Hz per second.

- Electronic Expansion Valve Control

The position of the electronic expansion valve (EXV) is controlled in steps from 0 (fully closed) to 480 (fully open).

At power-on: The EXV first closes fully, then moves to the standby position (480 (steps)). After compressor runs the EXV is controlled according to suction superheat discharge temperature, pressure, discharge temperature and compressor speed.

When the outdoor unit is in standby: The EXV is at position 480 (steps).



When the outdoor unit stops: The EXV first moves to 480 (steps) and remains for 30 seconds, then closes fully, then moves to the standby position (480 (steps)).

- Four-way Valve Control

The four-way valve is used to change the direction of refrigerant flow through the water side heat exchanger in order to switch between cooling and heating mode.

During heating operation, the four-way valve is on; during cooling and defrosting operations, the four-way valve is off.

- Fan

The speed of the outdoor unit fan is adjusted in steps, as shown below

Fan speed index	Fan speed (rpm)		
	MSC-70D2N8-A	MSC-90D2N8-A	MSC-120D2N8-A
W1	150	150	150
W2	200	200	200
W3	250	250	250
W4	300	300	300
W5	350	350	350
W6	400	400	400
W7	450	450	450
W8	530	530	530
W9	600	600	600
W10	650	650	650
W11	/	730	730
W12	/	780	780
W13	/	/	850

## 5 Special Control

### 5.1 Oil Return Operation

In order to prevent the compressor from running out of oil, the oil return operation is conducted to recover oil that has flowed out of the compressor and into the refrigerant piping. When the oil return operation is being conducted, the main PCB displays code d0.

The oil return operation starts when the following condition occurs:

- When the compressor cumulative operating time with running rotation speed less than 42rps reaches 6 hours.

The oil return operation ceases when any one of the following conditions occurs:

- Oil return operation duration reaches 5 minutes.
- Compressor stops.

For heating mode:

Component	Wiring diagram label	Control functions and states
Inverter compressor	COMP	Runs at oil return operation rotation speed
DC fan motor	FAN	Controlled according to heating mode
Electronic expansion valve	EXV	304 (steps)
Four-way valve	4-WAY	On

For cooling mode:

Component	Wiring diagram label	Control functions and states
Inverter compressor	COMP	Runs at oil return operation rotation speed
DC fan motor	FAN	Controlled according to cooling mode
Electronic expansion valve	EXV	304 (steps)
Four-way valve	4-WAY	Off

## 5.2 Defrosting Operation

- Normal defrosting

In order to recover heating capacity, the defrosting operation is conducted when the outdoor unit air side heat exchanger is performing as a condenser. The defrosting operation is controlled according to outdoor ambient temperature, air side heat exchanger refrigerant outlet temperature and the compressor running time.

- Manual defrosting

It can be active by setting on the wired controller, which is also aimed to help heat pump recover heating capacity quickly. Manual defrosting function will be deactivated automatically after normal defrosting.

Component	Wiring diagram label	Control functions and states
Inverter compressor	COMP	Runs at defrosting operation rotation speed
DC fan motor	FAN	Off
Electronic expansion valve	EXV	Fully open
Four-way valve	4-WAY	Off

## 5.3 Smart Grid function

The grid will provide two signals(EVU, SG) to indicate the grid load. Heat pump with Smart Grid function can identify different signals combination and adjust working state to adapt to the grid load. With the help of Smart Grid function, heat pump will give priority to use clean energy as much as possible to achieve energy saving and carbon reduction.

EVU signal	SG signal	Heating control	Cooling control
ON	ON	Boost heating mode (Heating capacity enhanced compared to normal heating mode)	Normal operation
ON	OFF	Boost heating mode (Heating capacity enhanced compared to normal heating mode)	Normal operation
OFF	ON	Normal operation	
OFF	OFF	Heat pump runs for certain time and then turns off.	



# Part 5

# Diagnosis and Troubleshooting

1 Electric wiring diagram.....	28
2 Electric Control Box Layout.....	29
3 PCB .....	30
4 Error Code Table.....	33
5 Troubleshooting .....	34
6 Temperature Sensor Resistance Characteristics .....	68
7 USB function .....	71

1 Electric wiring diagram

Version: D

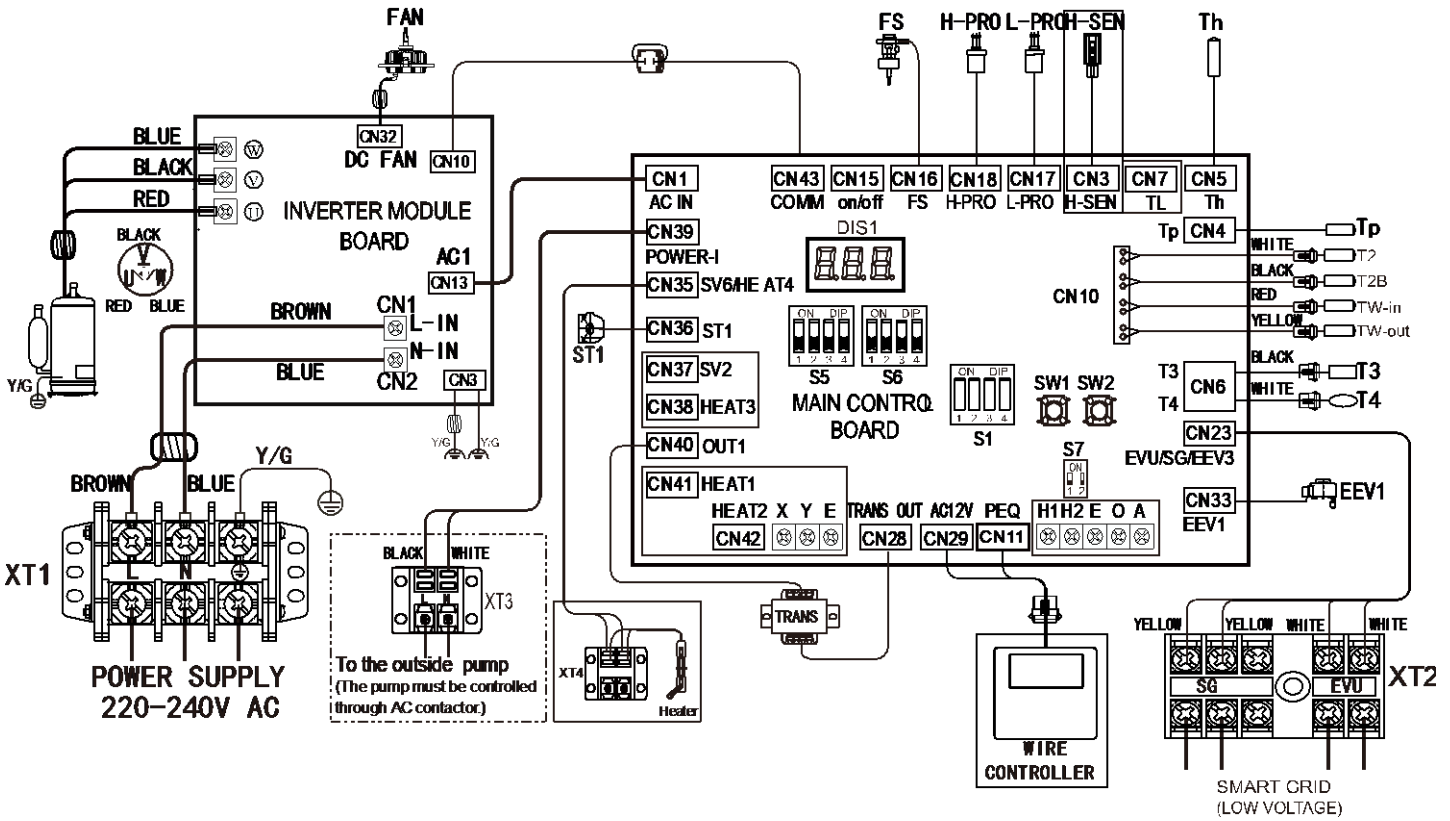

DIP switch settings

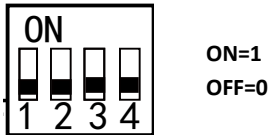

DIP Switch	1	2	3	4	Instruction
S1	0	0	0	0	1-phase for 7kW unit
	0	0	0	1	1-phase for 9kW unit
	0	0	1	0	1-phase for 12kW unit
	Other combinations				
S5	0	0	0	/	Factory default setting
	Other combinations			/	Reserved
	/	/	/	0	1-phase power supply
S6	/	/	/	1	Reserved
	0	/	/	/	External pump
	1	/	/	/	Reserved
	/	0	/	/	R32
	/	1	/	/	Reserved
	/	/	1	1	Swimming pool heat pump
Other combinations					Reserved

## 2 Electric Control Box Layout

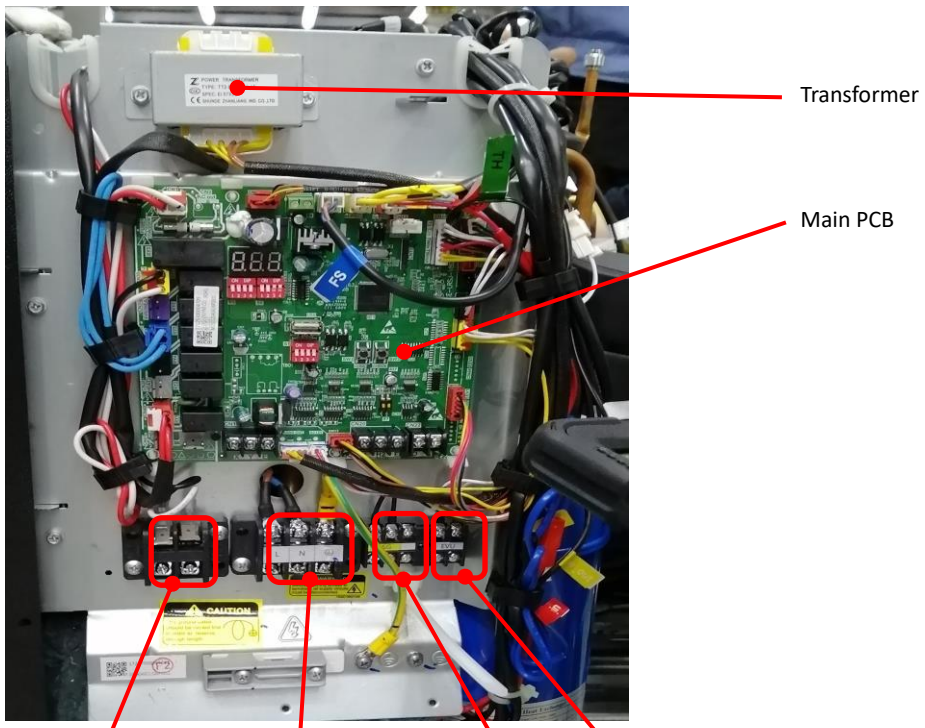
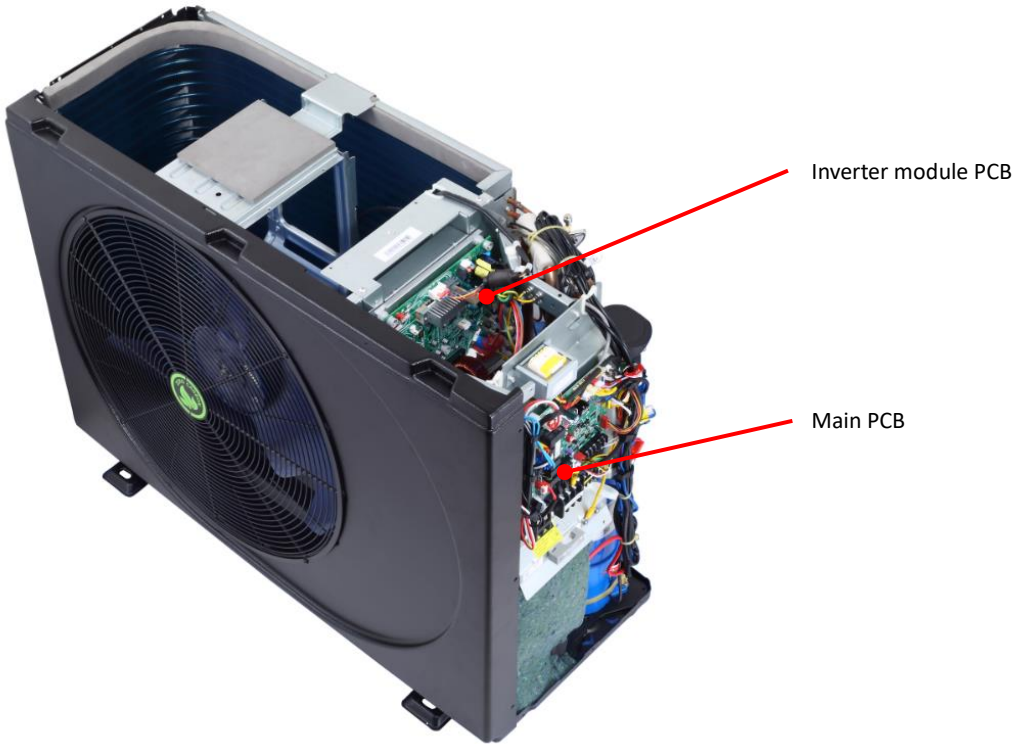

Terminal block for: External pump Power supply SG EVU

3 PCB

Main PCB

Midea ESG-Inv M Series Pool Heat Pump Manual

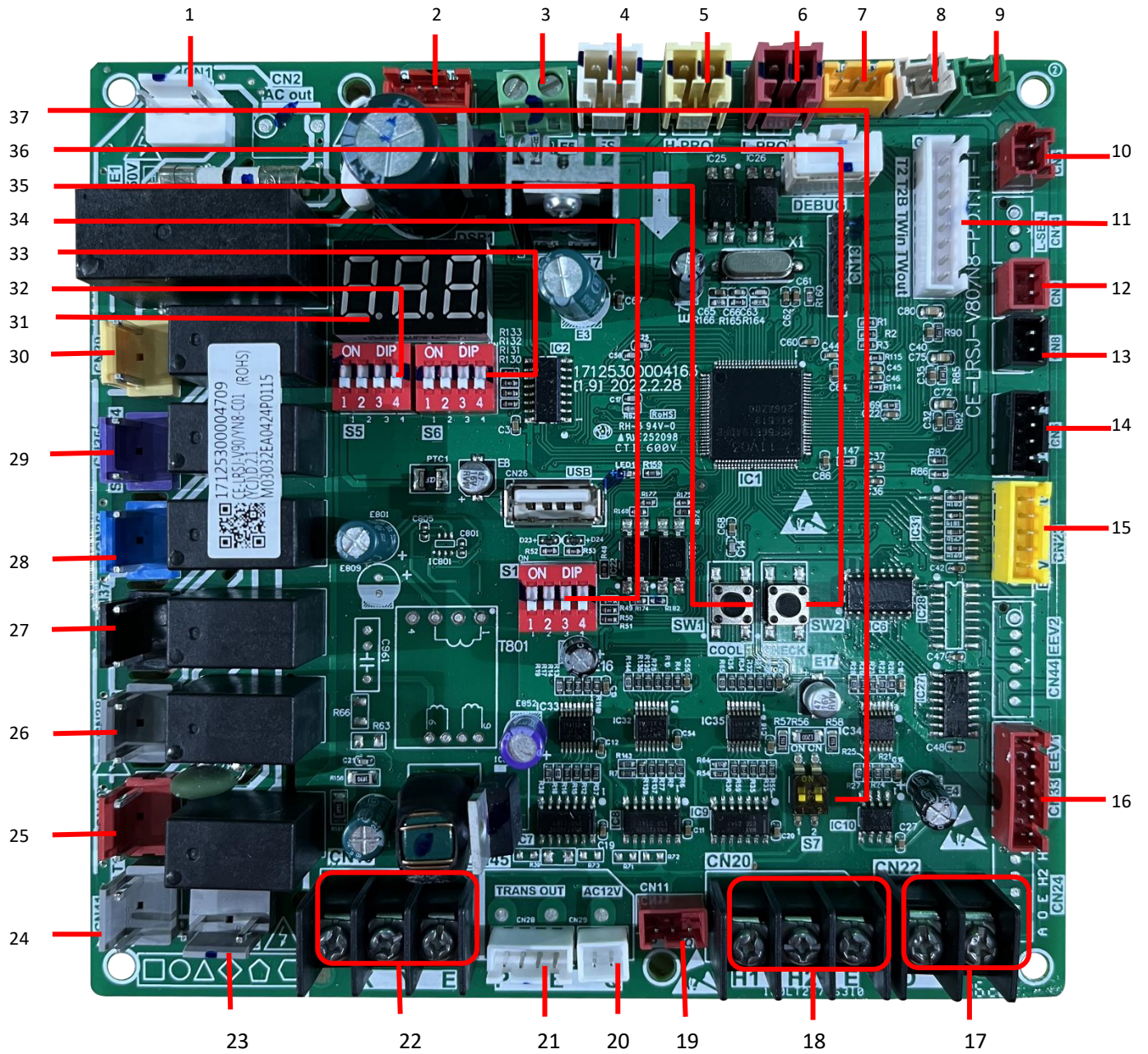

Label	Port	Content	Voltage(V)
1	CN1	Power input port from main control board	220VAC
2	CN43	Port for communication with Inverter module	12VDC/5VDC
3	CN15	Port for remote ON/OFF	3.3VDC
4	CN16	Port for flow switch	3.3VDC
5	CN18	Port for high pressure switch	3.3VDC
6	CN17	Port for low pressure switch	3.3VDC
7	CN3	Reserved	5VDC
8	CN7	Reserved	3.3VDC
9	CN5	Port for TH temperature sensor	3.3VDC
10	CN4	Port for TP temperature sensor	3.3VDC
11	CN10	Port for T2/T2B/TW-in/TW-out temperature sensor	3.3VDC

12	CN9	Reserved	3.3VDC
13	CN8	Reserved	3.3VDC
14	CN6	Port for T3,T4 temperature sensor	3.3VDC
15	CN23	Port for EEV3/SG EVU	3.3VDC
16	CN33	Port for electrical expansion valve1	12VDC
17	CN22	Reserved	5VDC
18	CN20	Reserved	5VDC
19	CN11	Port for communication with wired controller PQE	5VDC
20	CN29	Port for communication with wired controller AB	5VDC
21	CN28	Port for transformer output	5VDC
22	CN19	Reserved	5VDC
23	CN42	Reserved	220VAC
24	CN41	Reserved	220VAC
25	CN40	Port for transformer input	220VAC
26	CN38	Reserved	220VAC
27	CN37	Reserved	220VAC
28	CN36	Port for 4-way valve	220VAC
29	CN35	Port for plate heater	220VAC
30	CN39	Port for PUMP	220VAC
31	DSP1	Digital display	3.3VDC
32	S5	Dip switch	3.3VDC
33	S6	Dip switch	3.3VDC
34	S1	Dip switch	3.3VDC
35	SW1	Port for forced cooling	3.3VDC
36	SW2	Port for point check	3.3VDC
37	S7	Reserved	3.3VDC



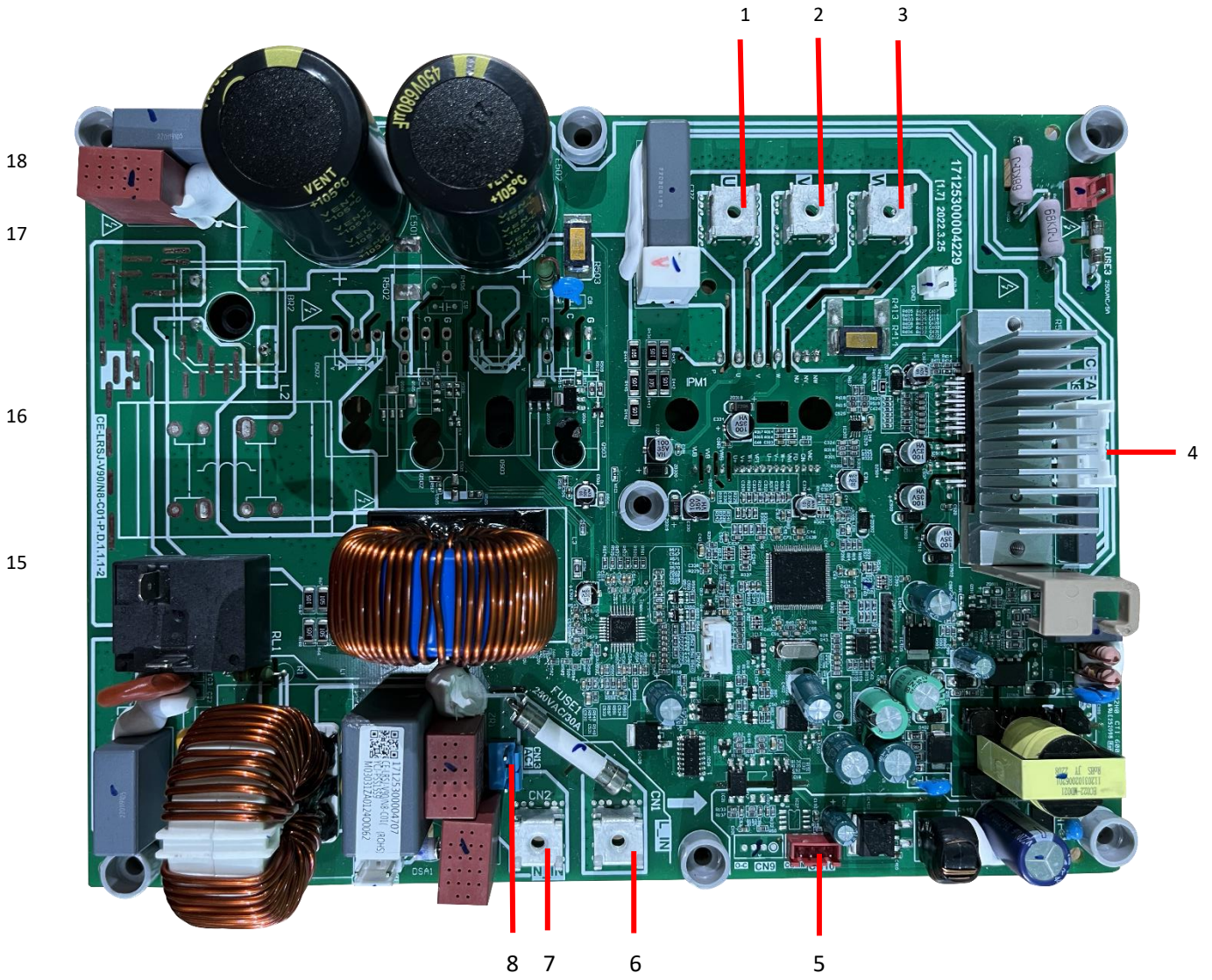

Label	Port	Content	Voltage(V)
1	U	Compressor connection port U	380VAC
2	V	Compressor connection port V	380VAC
3	W	Compressor connection port W	380VAC
4	CN32	Port for fan	380VAC
5	CN10	Port for communication with main control board	12VDC
6	CN1	Input port L for rectifier bridge	220VAC
7	CN2	Input port N for rectifier bridge	220VAC
8	CN13	Port for power supply	220VAC

## 4 Error Code Table

Error code	Content
bA	Ambient temp. sensor (T4) out of operation range
C7	High temperature protection of inverter module
E0	Water flow malfunction(after 3 times E8)
E2	Communication malfunction between controller and main control board
E5	Air side heat exchanger temperature sensor (T3)malfunction
E6	The ambient temperature sensor (T4)malfunction
E8	Water flow malfunction
E9	Suction temperature sensor(Th) malfunction
EA	Discharge temperature sensor(Tp) malfunction
Ed	Inlet water temperature sensor (TW-in) malfunction
EE	EEprom malfunction
F1	DC bus low voltage protection
F6	EXV1 fault
H1	Communication malfunction between main control board and inverter board
H2	Liquid refrigerant temperature sensor(T2) malfunction
H3	Gas refrigerant temperature sensor(T2B) malfunction
H4	Three times L0 protection
H6	The DC fan malfunction
H7	Voltage protection
H8	HP pressure sensor malfunction
HA	Outlet water temperature sensor (TW-out) malfunction
Hb	Three times PP protection and TW-out below 7 °C
HF	Inverter module board EE prom malfunction
HH	10 times H6 in 2 hours
HP	Low pressure protection in cooling mode
P0	Low pressure switch protection
P1	High pressure switch protection
P3	Compressor overcurrent protection
P4	Comp discharge temp. too high protection
P5	TW-out-TW-in  value too big protection
Pb	Anti-freeze mode
PP	TW-out-TW-in  abnormal protection
Pd	High temperature protection of air side heat exchanger temperature(T3)
L0	Inverter or compressor protection
L1	DC bus low voltage protection
L2	DC bus high voltage protection
L3	Current sampling error of PFC circuit
L4	Rotating stall protection
L5	Zero speed protection
L7	Phase loss protection of compressor

## 5 Troubleshooting

### 5.1 Warning

#### Warning



- All electrical work must be carried out by competent and suitably qualified, certified and accredited professionals and in accordance with all applicable legislation (all national, local and other laws, standards, codes, rules, regulations and other legislation that apply in a given situation).
- Power-off the outdoor units before connecting or disconnecting any connections or wiring, otherwise electric shock (which can cause physical injury or death) may occur or damage to components may occur.

### 5.2 How to judge whether the temperature sensor is normal

Measure sensor resistance.

If the resistance is not consistent with the sensor resistance characteristics table, the sensor has failed. Please refer to “6 Temperature Sensor Resistance Characteristics” for more details.

### 5.3 Normal operating parameters range

These parameters will help to judge if the unit is in normal operation.

Cooling mode						
Outdoor ambient temperature	°C	<25	25 to 30	30 to 35	35 to 40	>40
Discharge temperature	°C	52-62	54-68	62-74	64-80	73-85
Discharge superheat	°C	15-42	15-38	15-39	15-40	21-40
Discharge pressure	MPa	1.6-2.2	1.9-2.4	2.2-2.7	2.5-3.1	2.8-3.3
Suction pressure	MPa	0.7-1.3	0.7-1.3	0.7-1.3	0.7-1.3	0.7-1.3
DC inverter compressor current	A	1-7	1-8	1-8	2-7	2-7

Cooling mode						
Outdoor ambient temperature	°C	< 10	10 to 20	20 to 30	30 to 40	> 40
Discharge temperature	°C	43-97	48-97	48-98	48-98	50-98
Discharge superheat	°C	18-40	18-39	18-40	18-40	20-40
Discharge pressure	MPa	1.7-3.8	1.9-3.8	1.9-3.8	1.9-3.8	1.9-3.8
Suction pressure	MPa	0.8-1.4	1.3-1.6	1.3-1.6	1.3-1.6	1.3-1.6
DC inverter compressor current	A	1-12	1-11	1-10	1-9	1-8

5.4 bA Troubleshooting

5.4.1 Digital display output



5.4.2 Procedure

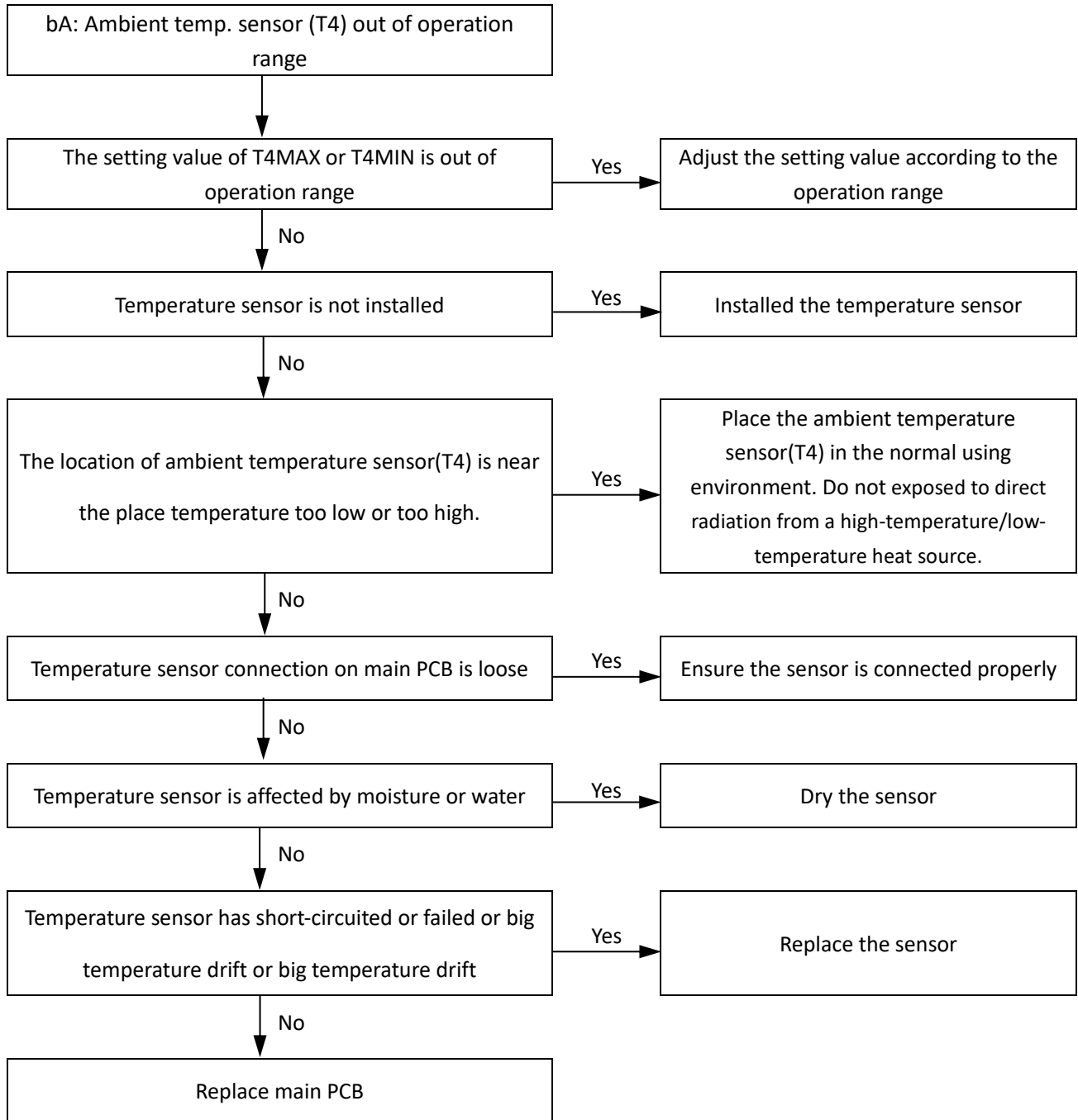

Note:

1. Ambient temp. sensor (T4) connection is port CN6 on main PCB.

5.5 C7 Troubleshooting

5.5.1 Digital display output



5.5.2 Procedure

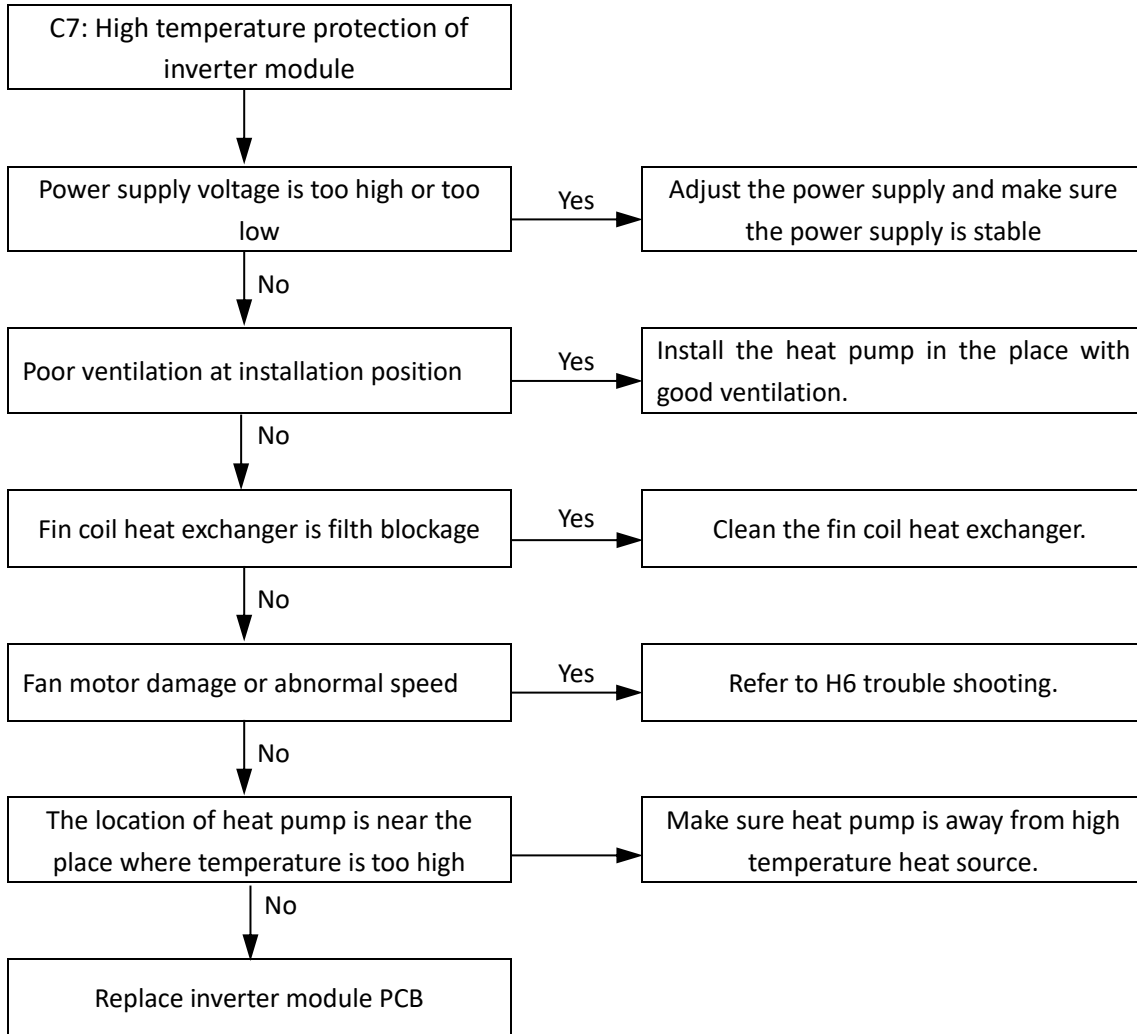

5.5.3 Protection logic

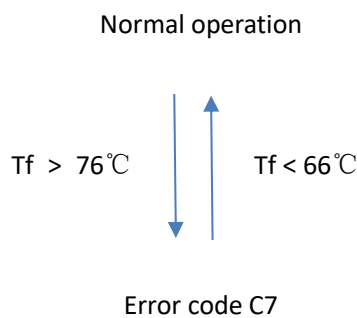

Note:

1.  $T_f$  means inverter module PCB temperature, which is detected by the inverter module PCB itself.

5.6 E0, E8 Troubleshooting

5.6.1 Digital display output

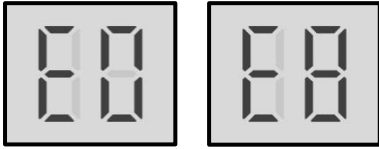

5.6.2 Procedure

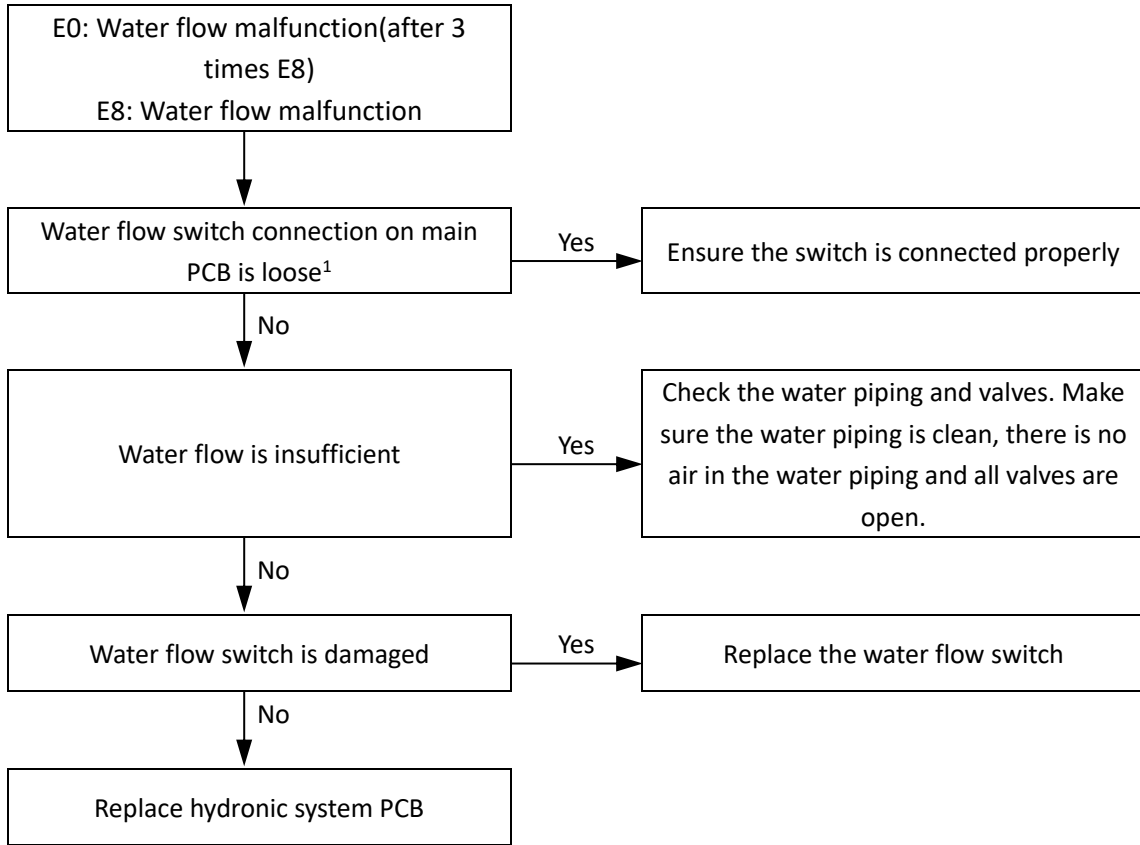

Note:

- 2. Water flow switch connection is port CN16 on the refrigerant system PCB

5.8 E2 Troubleshooting

5.8.1 Digital display output



5.8.2 Procedure

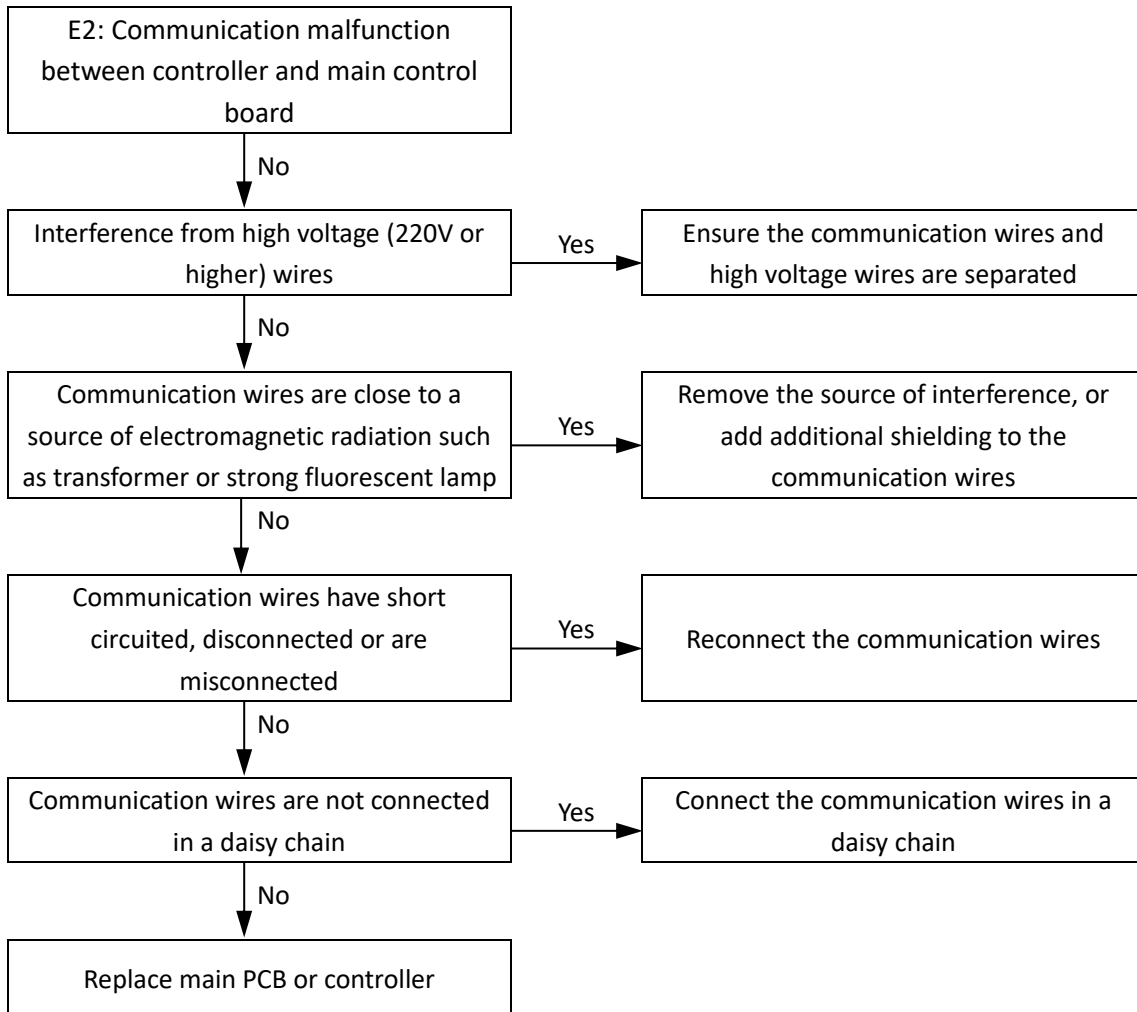

5.9 E3, E5, E6, E9, EA, Ed, H2, H3, HA Troubleshooting

5.9.1 Digital display output

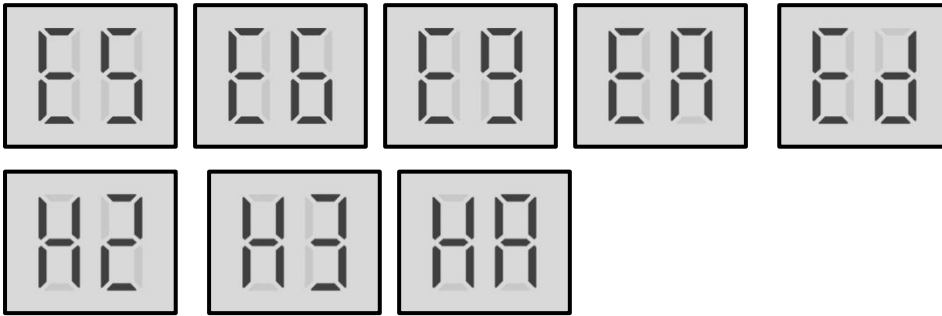

5.9.2 Procedure

E5: ODU heat exchanger temperature sensor error (T3)  
 E6: ODU ambient temperature sensor error (T4)  
 E9: Suction temperature sensor error (Th)  
 EA: Discharge temperature sensor error (Tp)  
 Ed: Inlet water temperature sensor (TW-in) malfunction  
 H2: Liquid refrigerant temperature sensor(T2) malfunction  
 H3: Gas refrigerant temperature sensor(T2B) malfunction  
 HA: Outlet water temperature sensor (TW-out) malfunction

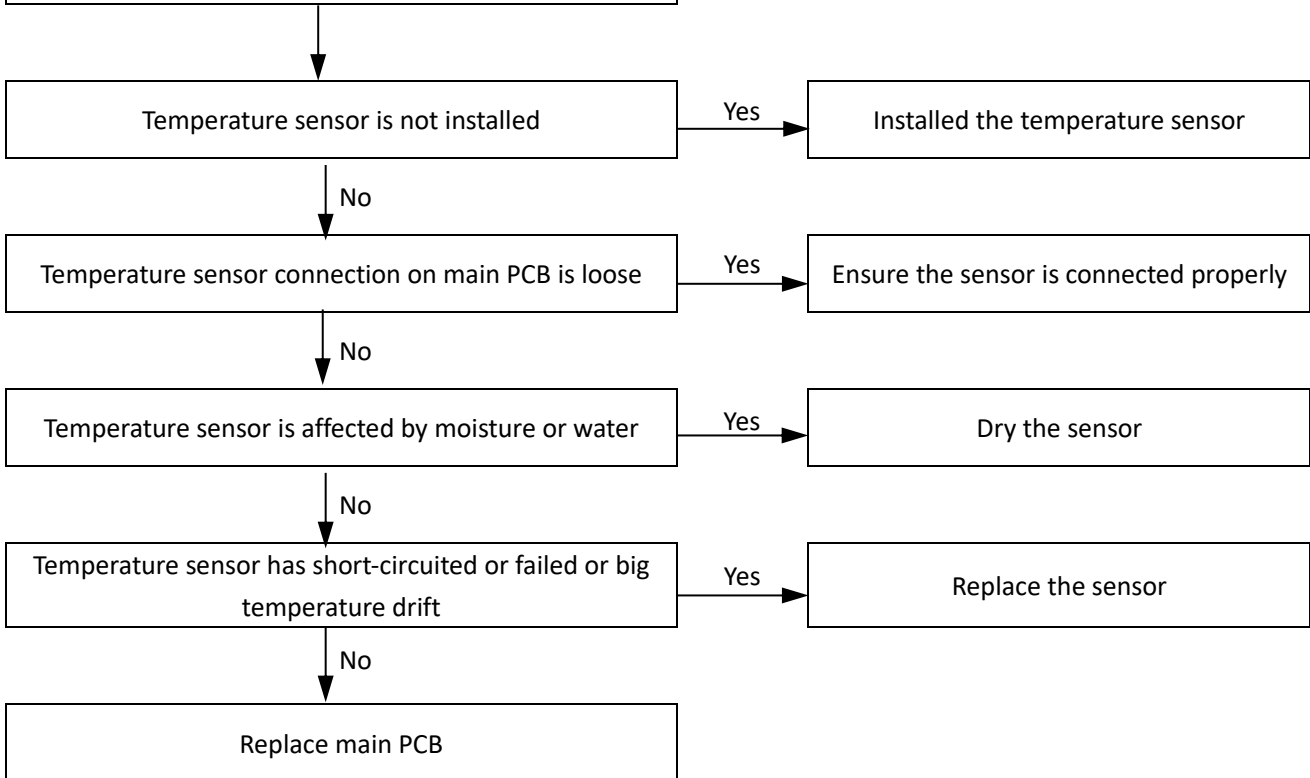

Note:

1. ODU heat exchanger temperature sensor(T3), ODU ambient temperature sensor(T4) connection is port CN6 on the refrigerant system PCB  
 Suction temperature sensor(Th) connection is port CN5 on the refrigerant system PCB



Discharge temperature sensor(Tp) connection is port CN4 on the refrigerant system PCB

Inlet water temperature sensor (TW-in) connection, Outlet water temperature sensor (TW-out), Liquid refrigerant temperature sensor(T2), Gas refrigerant temperature sensor(T2B) malfunction is port CN10 on the refrigerant system PCB

## 5.10 EF Troubleshooting

### 5.10.1 Digital display output



### 5.10.2 Procedure

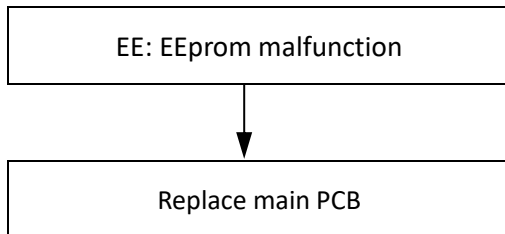

5.11 F1 Troubleshooting

5.11.1 Digital display output



5.11.2 Procedure

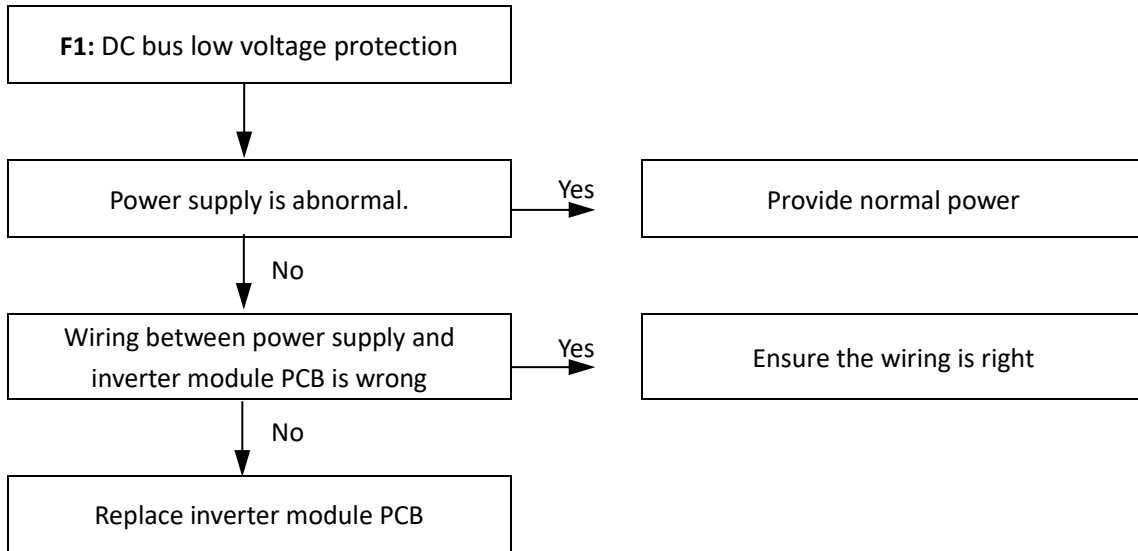

## 5.12 F6 Troubleshooting

### 5.12.1 Digital display output



### 5.12.2 Procedure

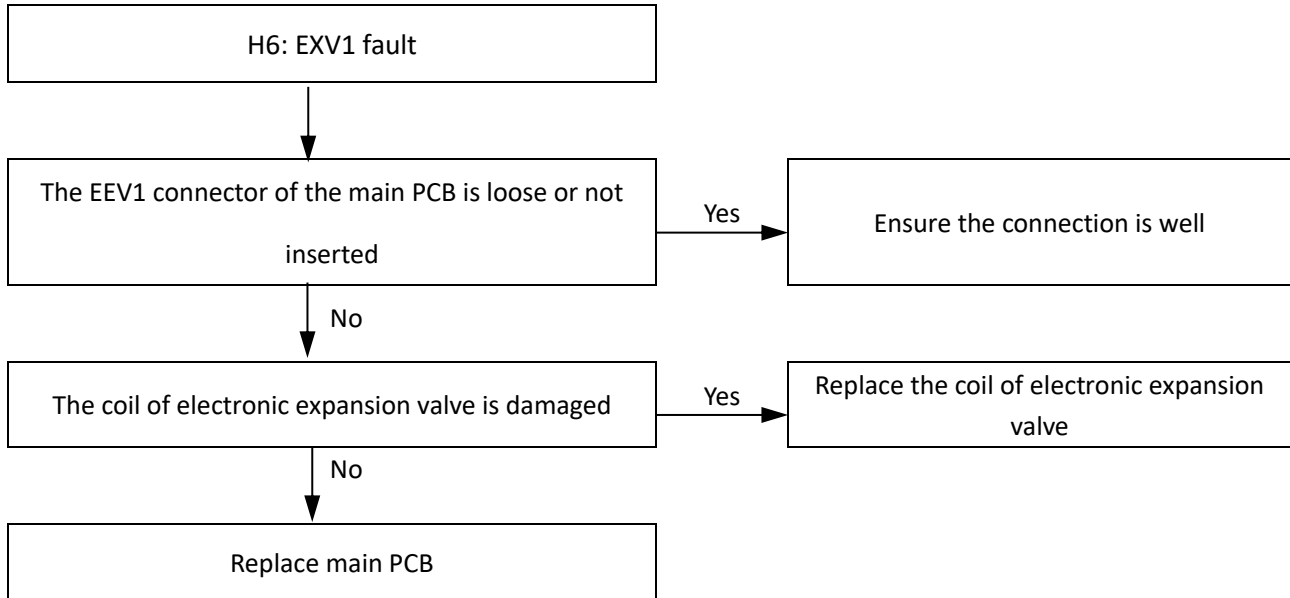

Note:

1. EXV connection is port CN33 on the main PCB

## 5.13 H1 Troubleshooting

### 5.13.1 Digital display output



### 5.13.2 Procedure

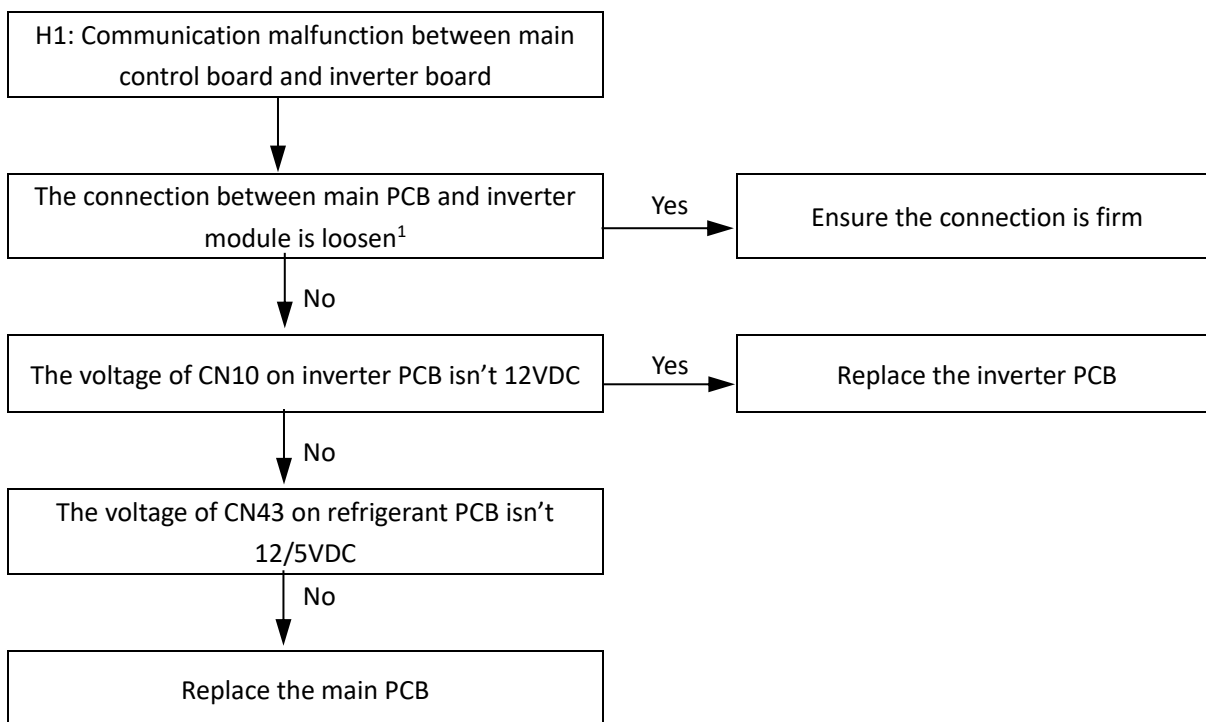

Note:

1. The connection is between CN43 on the main PCB and CN10 on the Inverter module PCB.

## 5.14 H4 Troubleshooting

### 5.14.1 Digital display output



### 5.14.2 Description

- H4 indicates three times L0 protection in one hour
- Heat pump stops running.
- Error code is displayed on the refrigerant system PCB digital tube and user interface..

### 5.14.3 Procedure

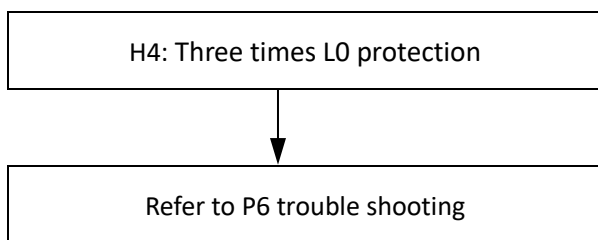

5.15 H6, HH Troubleshooting

5.15.1 Digital display output

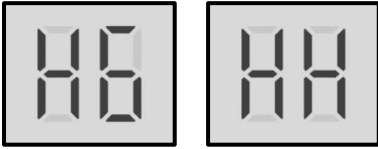

5.15.2 Procedure

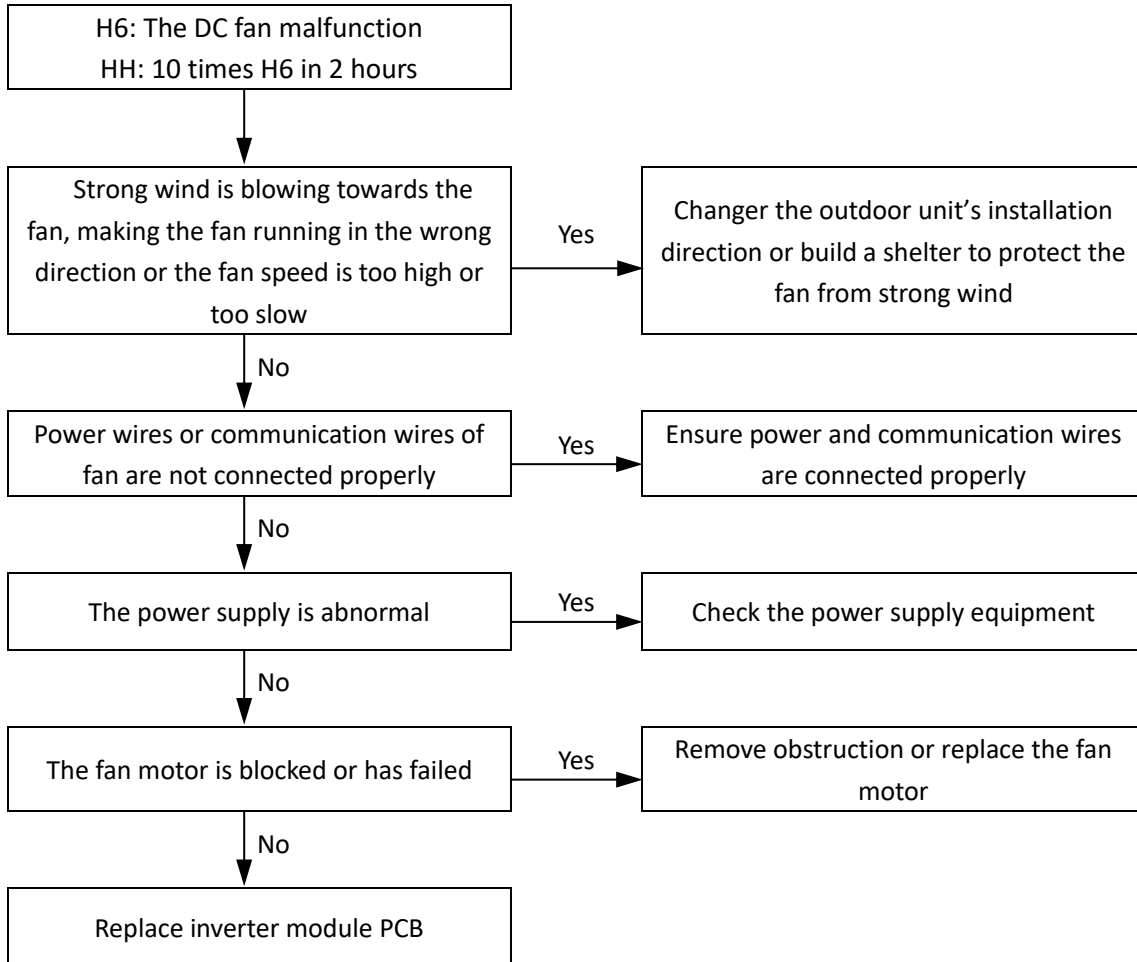

5.15.3 Protection logic

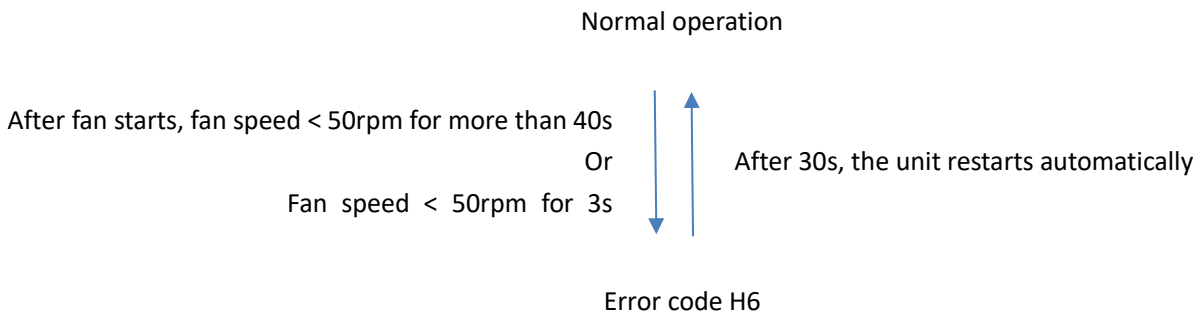

When H6 protection occurs 10 times in 120 minutes, the HH error is displayed. When an HH error occurs, a manual system restart is required before the system can resume operation.

5.16 H7 Troubleshooting

5.16.1 Digital display output



5.16.2 Procedure

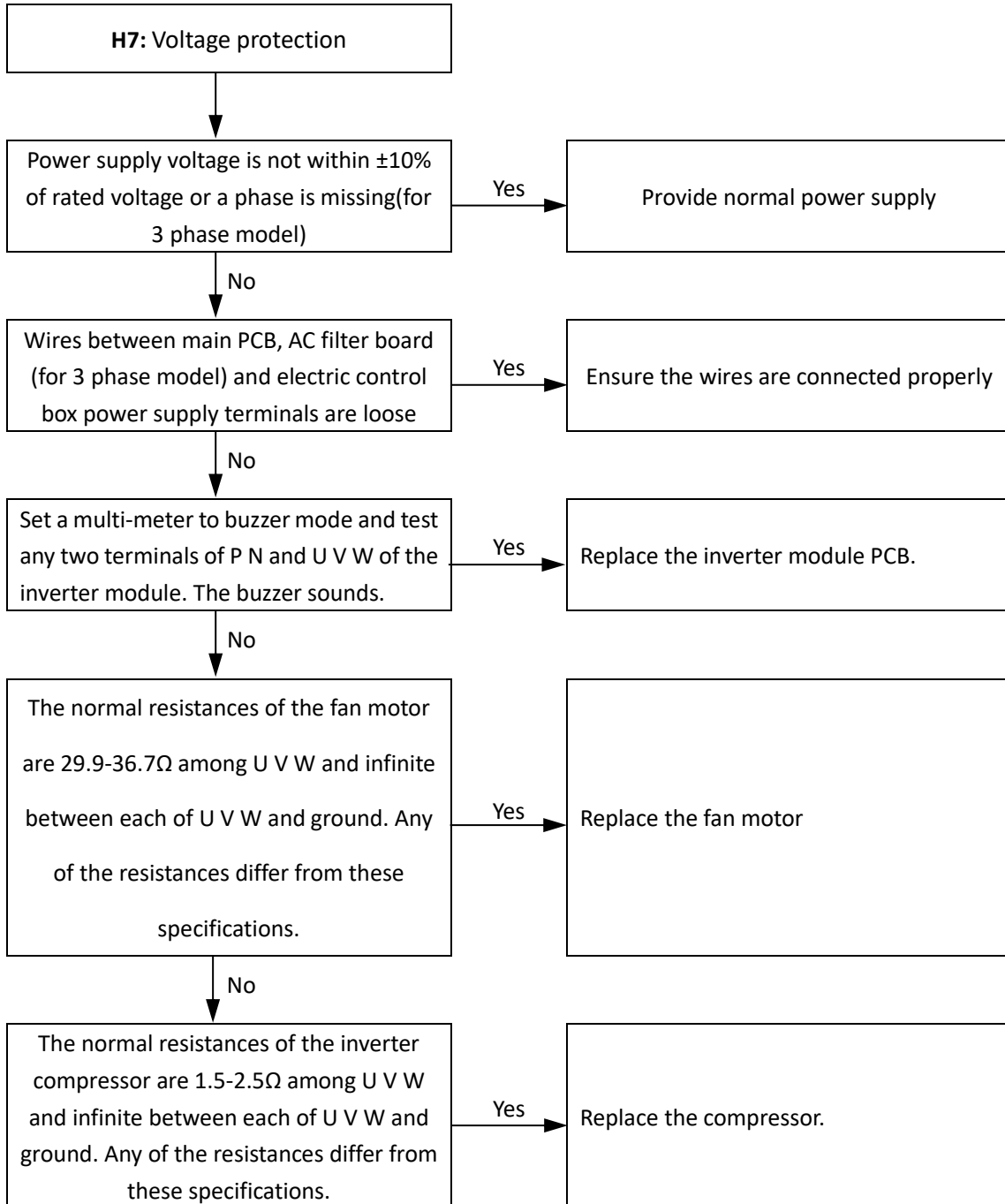



5.16.3 Protection logic

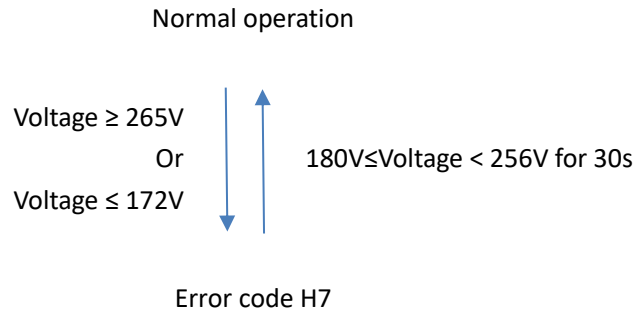

5.17 H8 Troubleshooting

5.17.1 Digital display output



5.17.2 Procedure

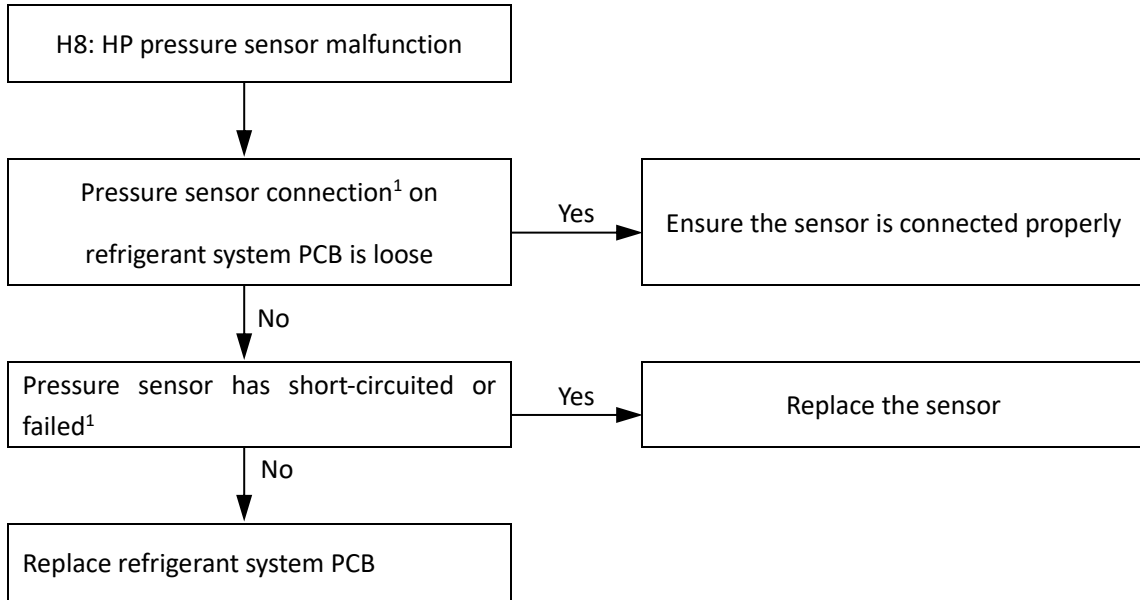

Note:

- 1. Pressure sensor connection is port CN3 on the main PCB.

5.18 Hb, PP Troubleshooting

5.18.1 Digital display output

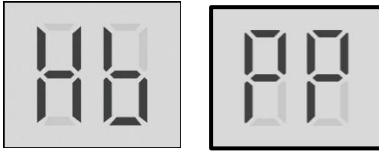

5.18.2 Procedure

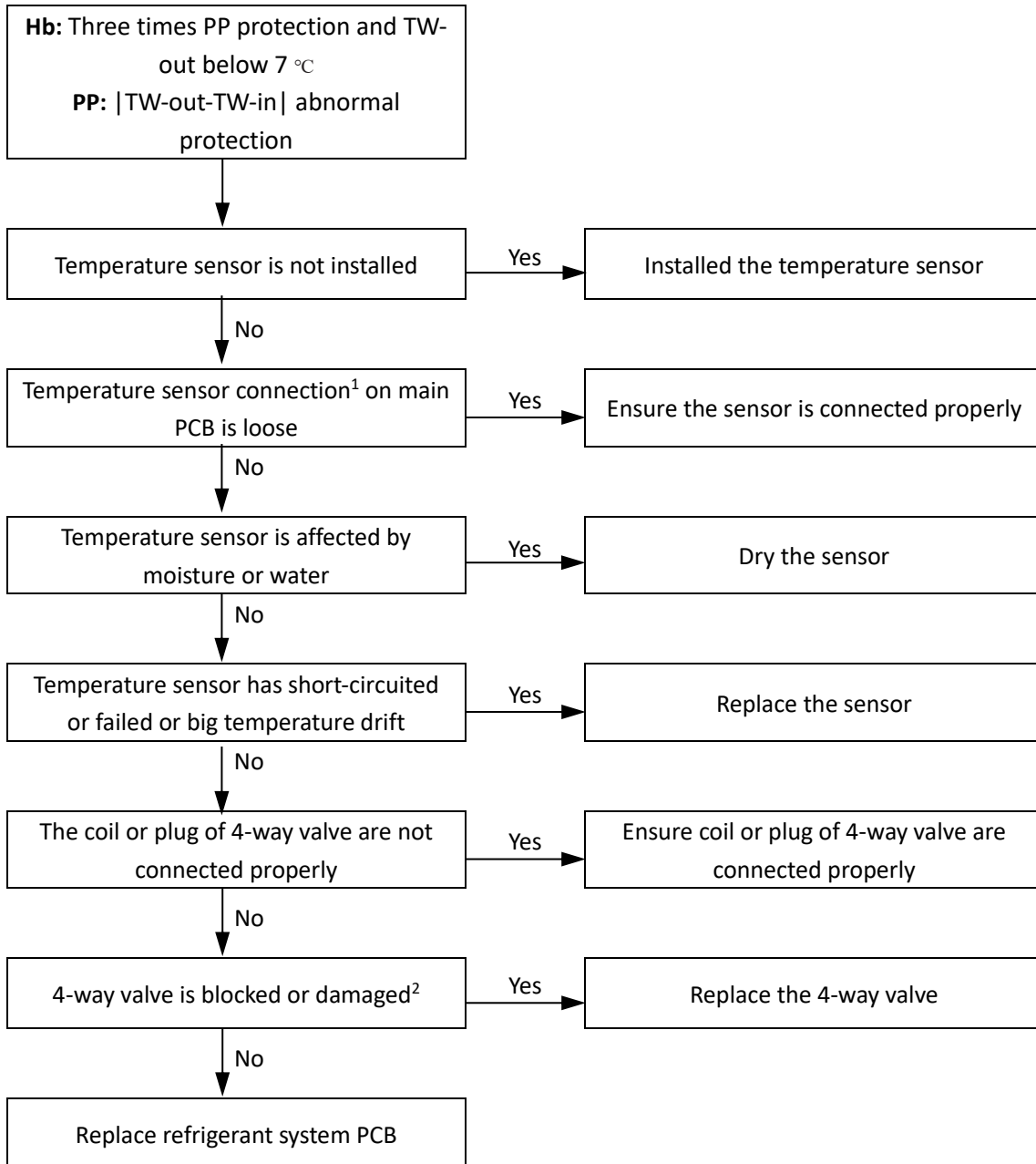

- Note:
1. Inlet water temperature sensor(TW-in), outlet water temperature sensor(TW-out) connection are port CN10 on the refrigerant system PCB.
  2. Restart the unit in cooling mode to change the refrigerant flow direction. If the unit does not operate normally, the 4-way valve is blocked or damaged.

### 5.19 HF Troubleshooting

#### 5.19.1 Digital display output



#### 5.19.2 Procedure

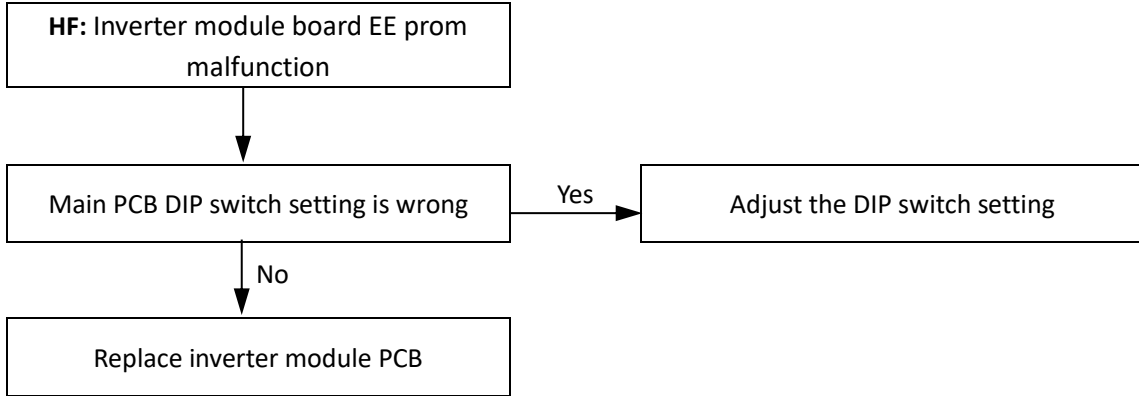

5.20 HP, P0 Troubleshooting

5.20.1 Digital display output

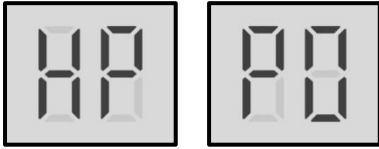

5.20.2 Procedure



Replace main PCB

**Notes:**

1. Low pressure switch connection is port CN17 on the main PCB.
2. An insufficiency of refrigerant causes compressor discharge temperature to be higher than normal, discharge and suction pressures to be lower than normal and compressor current to be lower than normal, and may cause frosting to occur on the suction pipe. These issues disappear once sufficient refrigerant has been charged into the system.
3. A low pressure side blockage causes compressor discharge temperature to be higher than normal, suction pressure to be lower than normal and compressor current to be lower than normal, and may cause frosting to occur on the suction pipe. For normal system parameters.
4. Outlet water temperature sensor (TW-out) connection is port CN10 on the main PCB
5. Measure the resistance among the three terminals of the pressure sensor. If the resistance is of the order of mega Ohms or infinite, the pressure sensor has failed.

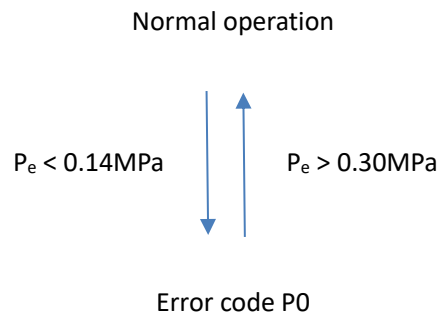
**5.20.3 Protection logic**

When P0 protection occurs 3 times in 60 minutes, the HP error is displayed. When an HP error occurs, a manual system restart is required before the system can resume operation.

**Note:**

Pe: Suction pressure

5.21 P1 Troubleshooting

5.21.1 Digital display output



5.21.2 Procedure

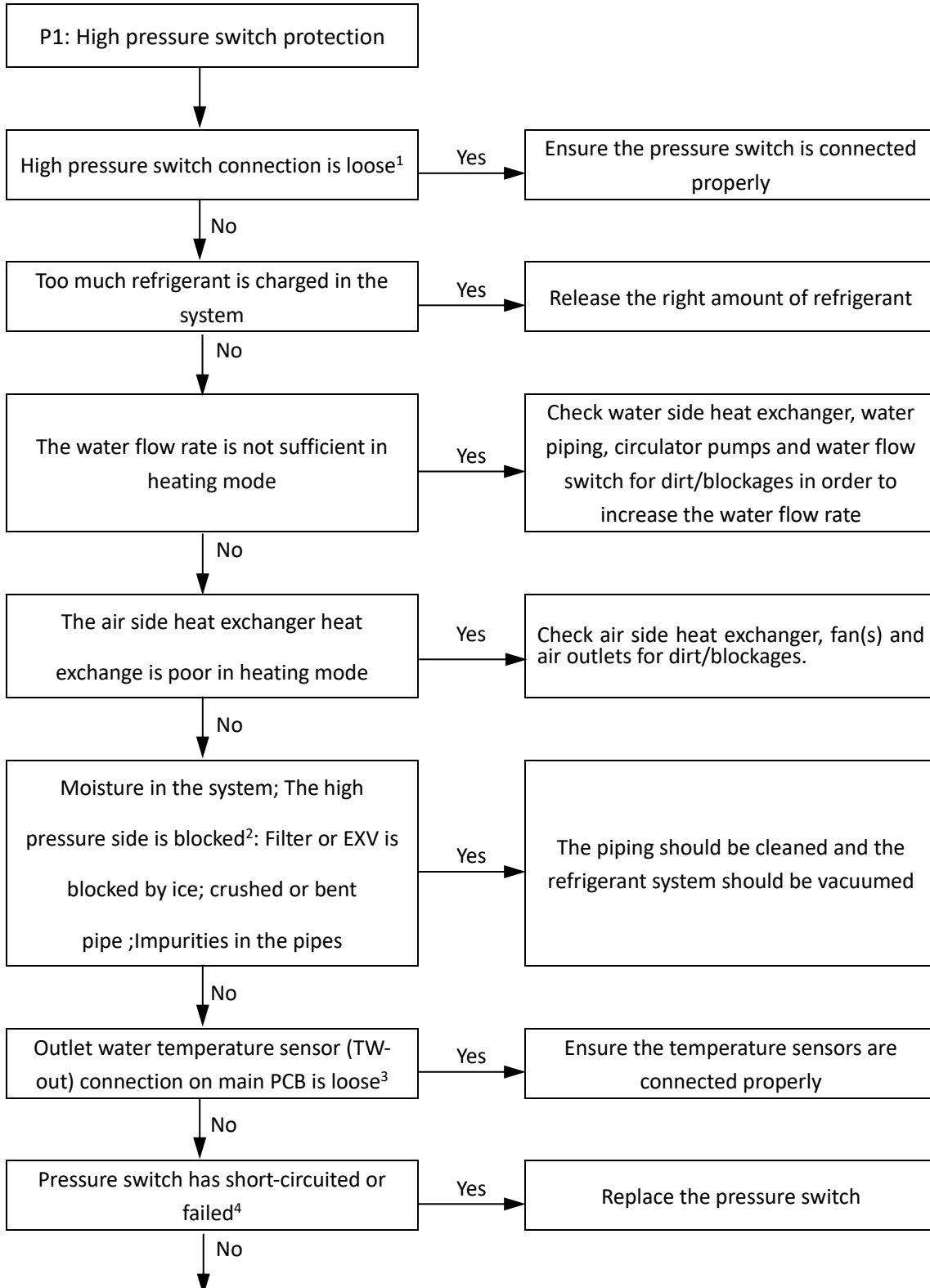

Replace main PCB

Notes:

1. High pressure switch connection is port CN18 on the main PCB.
2. High pressure side blockage causes discharge temperature to be higher than normal, discharge pressure to be higher than normal and suction pressure to be lower than normal.
3. Outlet water temperature sensor (TW-out) connection is port CN10 on the hydro system PCB.
4. Measure the resistance among the terminals of the pressure switch. If the resistance is of the order of mega Ohms or infinite, the pressure switch has failed.

### 5.21.3 Protection logic

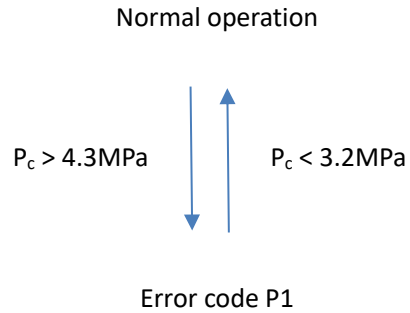

Note:

Pc: Discharge pressure



5.22 P3 Troubleshooting

5.22.1 Digital display output



5.22.2 Procedure

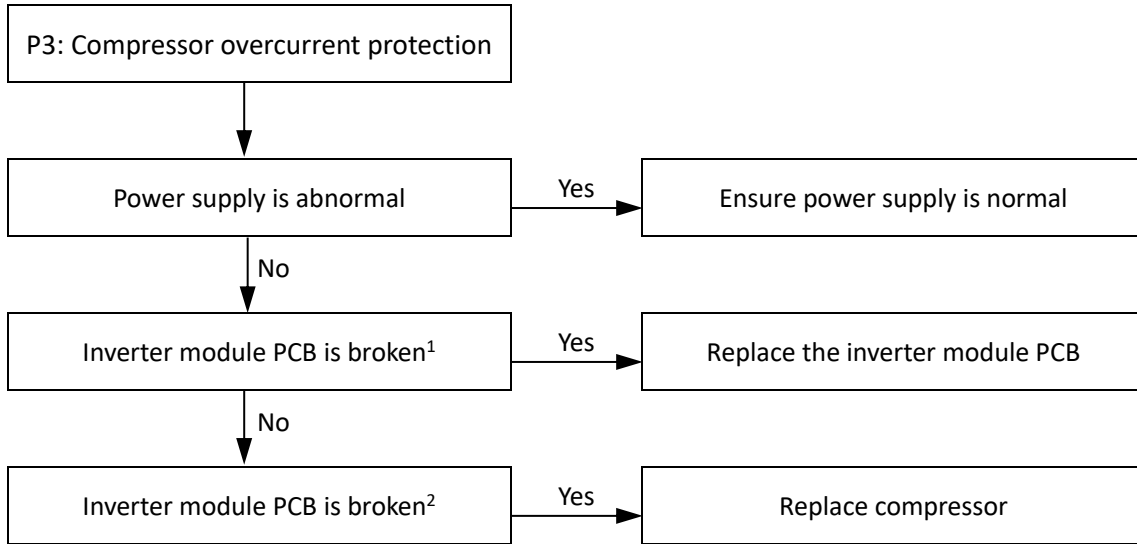

- Notes:
1. Set a multi-meter to buzzer mode and test any two terminals of P N and U V W of the inverter module. If the buzzer sounds, the inverter module has short-circuited.
  2. The normal resistances of the inverter compressor are 1.5-2.5Ω among U V W and infinite between each of U V W and ground. If any of the resistances differ from these specifications, the compressor has malfunctioned.

5.22.3 Protection logic

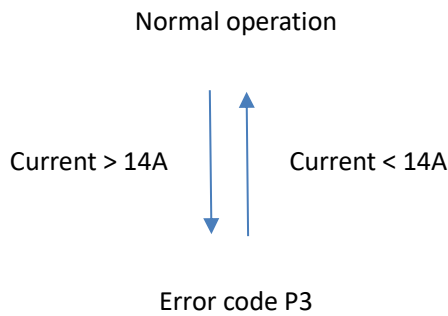

### 5.23 P4 Troubleshooting

#### 5.23.1 Digital display output



#### 5.23.2 Procedure

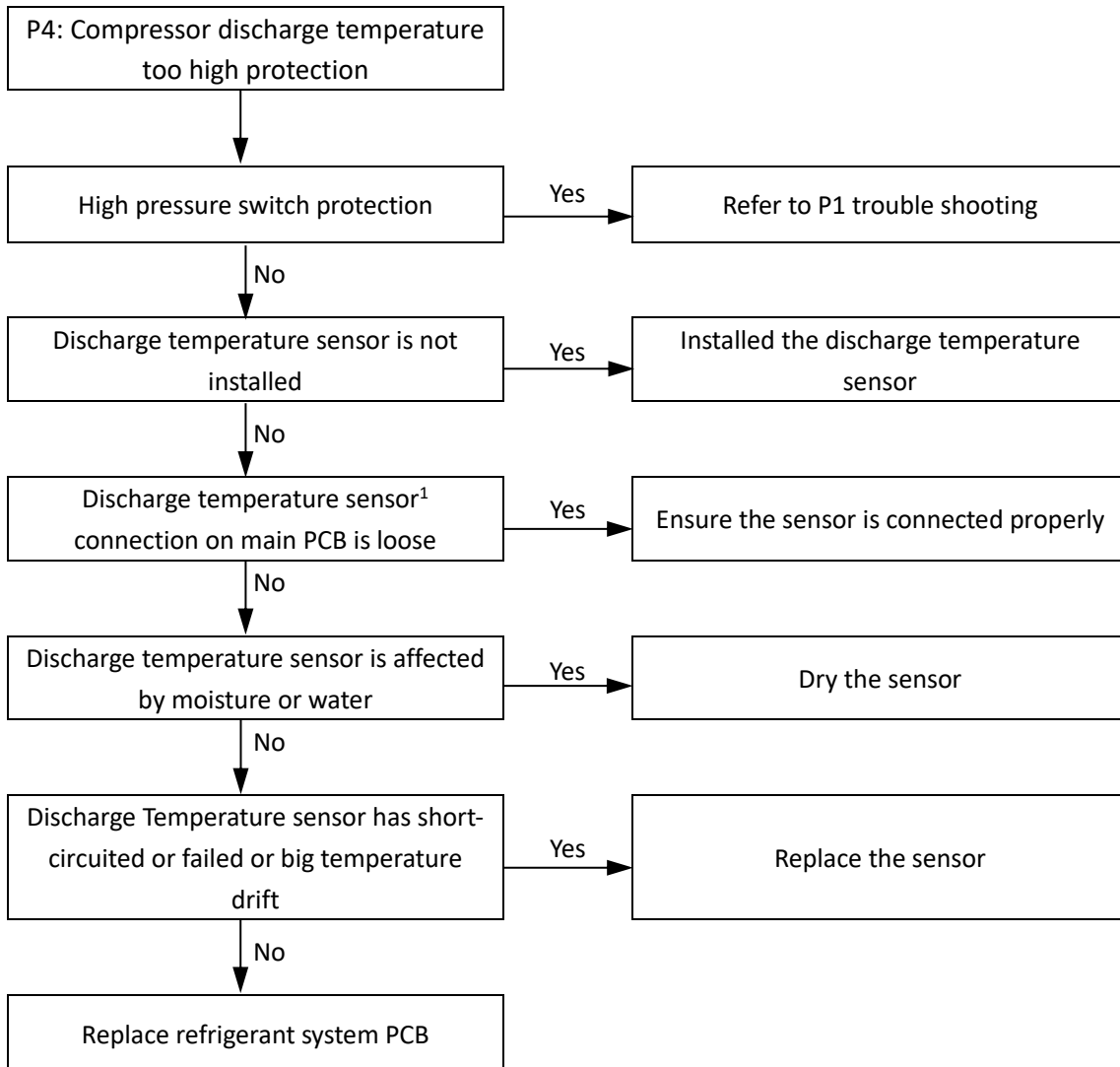

Notes:

1. Discharge temperature sensor (Tp) connection is port CN4 on the refrigerant system PCB.

#### 5.23.3 Protection logic

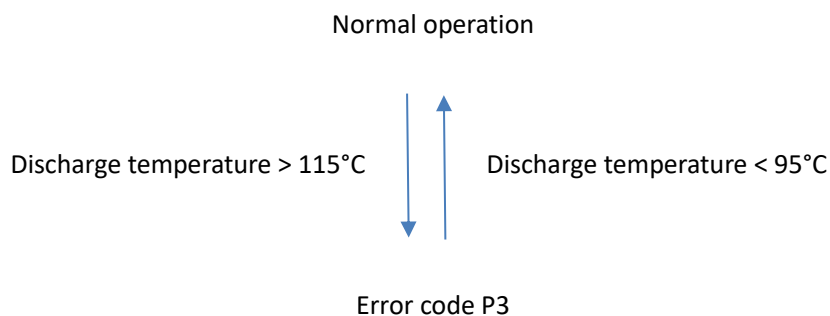

5.24 P5 Troubleshooting

5.24.1 Digital display output



5.24.2 Procedure

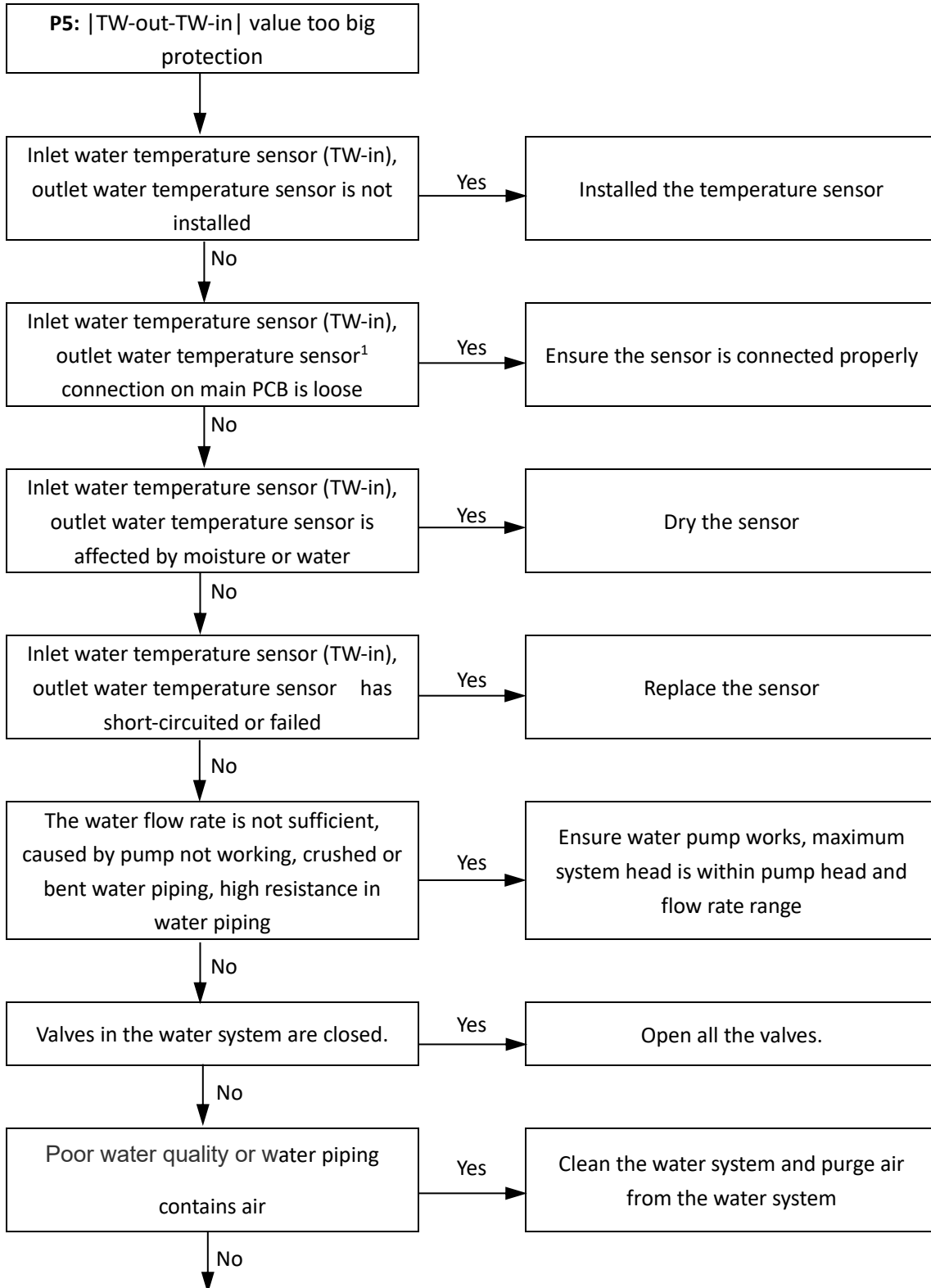

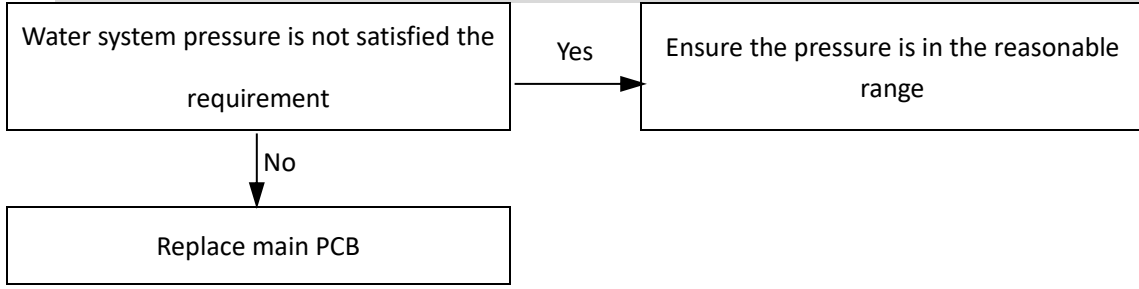

Notes:

1. Inlet water temperature sensor (TW-in) connection, outlet water temperature sensor (TW-out) connection is port CN10 on the main PCB.

5.25 Pb Troubleshooting

5.25.1 Digital display output



5.25.2 Protection logic

Pb: Anti-freeze mode

Anti-freeze is used to protect the water system from cracking during winter. It is normal protection operation and heat pump will return to the normal operation automatically.

Heating mode

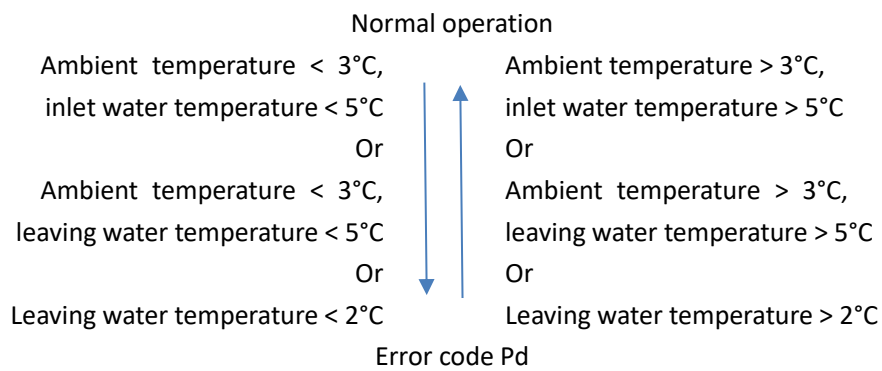

Cooling mode

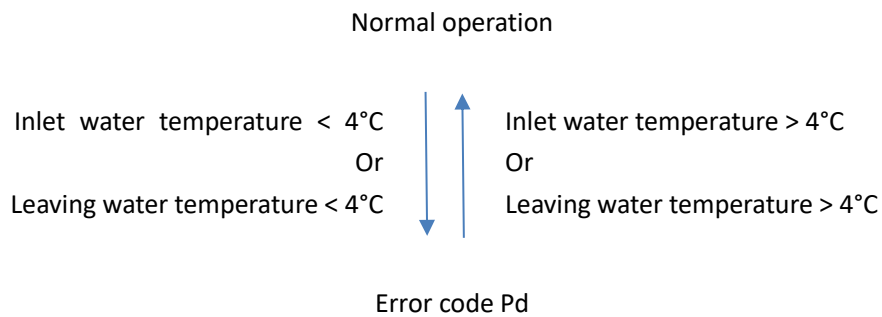

5.26 Pd Troubleshooting

5.26.1 Digital display output



5.26.2 Procedure

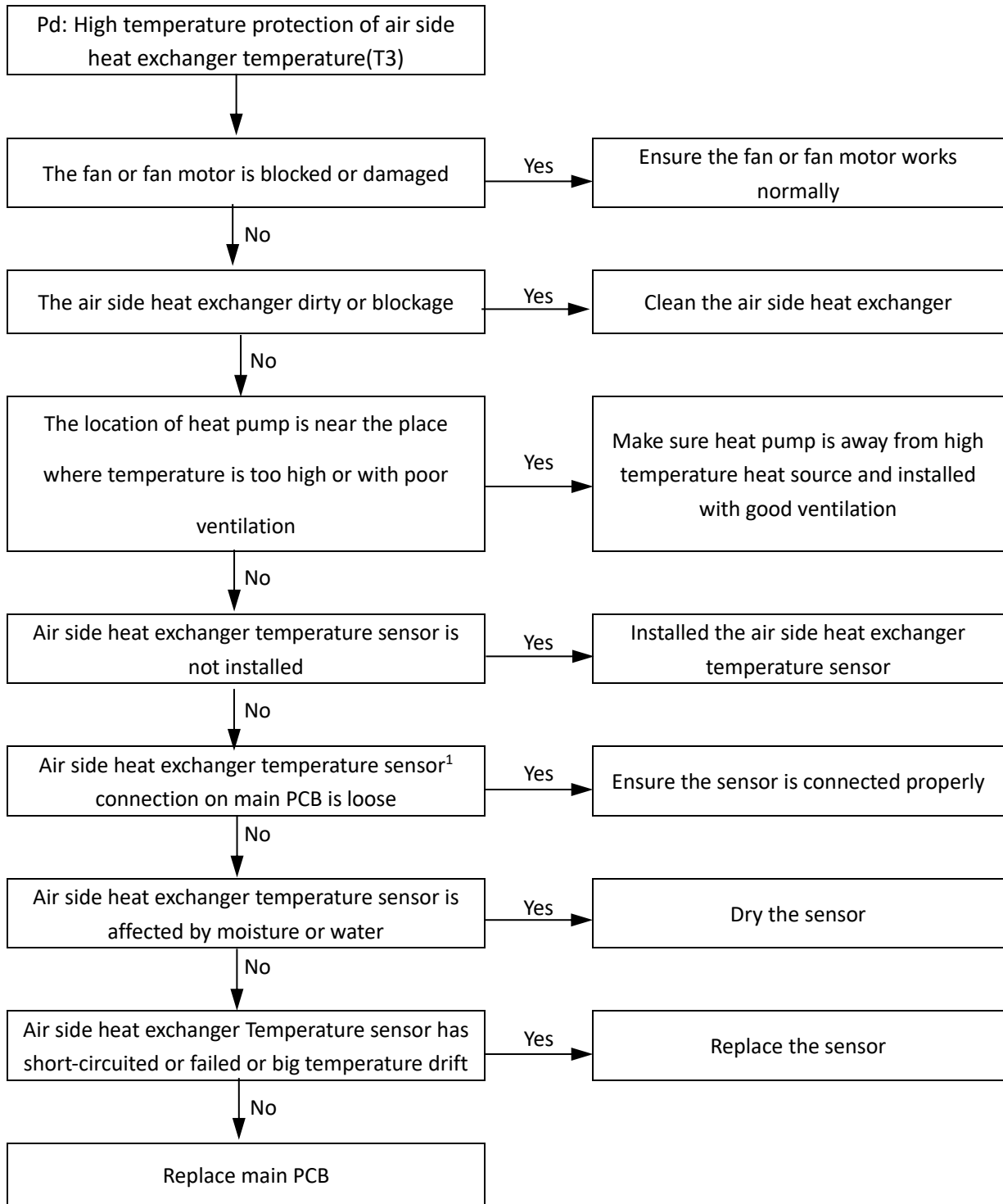

Notes:

1. Air side heat exchanger temperature sensor (T3) connection is port CN6 on the refrigerant system PCB.

5.26.3 Protection logic

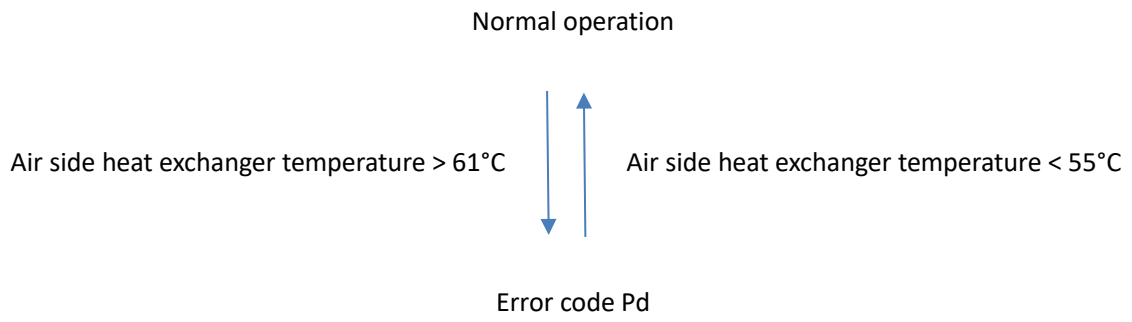

## 5.27 Inverter module Troubles shooting for single-phase models

### 5.27.1 Digital display output



### 5.27.2 Description

- L0 indicates Inverter or compressor protection
- L1 indicates DC bus low voltage protection
- L2 indicates DC bus high voltage protection
- L3 indicates current sampling error of PFC circuit
- L4 indicates rotating stall protection
- L5 indicates zero speed protection
- L7 indicates phase loss protection of compressor

The specific error codes can also be obtained from the LED indicators on the inverter module.

LED1 flashing pattern (RED)	Corresponding error
Flashes 1 times and stops for 0.4s, then repeats	L0 indicates Inverter or compressor protection(overcurrent)
Flashes 2 times and stops for 0.4s, then repeats	L0 indicates Inverter or compressor protection(overheated)
Flashes 3 times and stops for 0.4s, then repeats	L1 indicates DC bus low voltage protection
Flashes 3 times and stops for 0.4s, then repeats	L2 indicates DC bus high voltage protection
Flashes 4 times and stops for 0.4s, then repeats	L3 indicates current sampling error of PFC circuit
Flashes 5 times and stops for 0.4s, then repeats	L4 indicates rotating stall protection
Flashes 5 times and stops for 0.4s, then repeats	L5 indicates zero speed protection
Flashes 6 times and stops for 0.4s, then repeats	L7 indicates phase loss protection of compressor

LED location of inverter module

Inverter Module: LED1

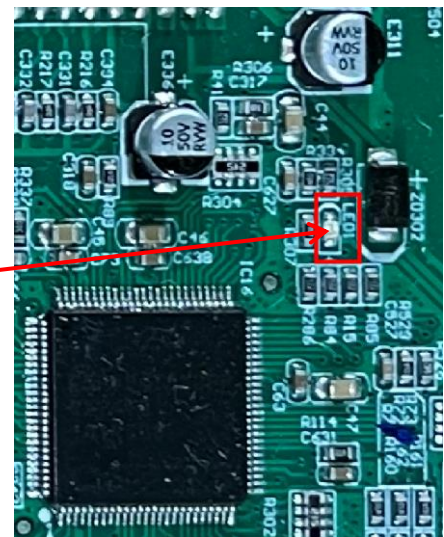
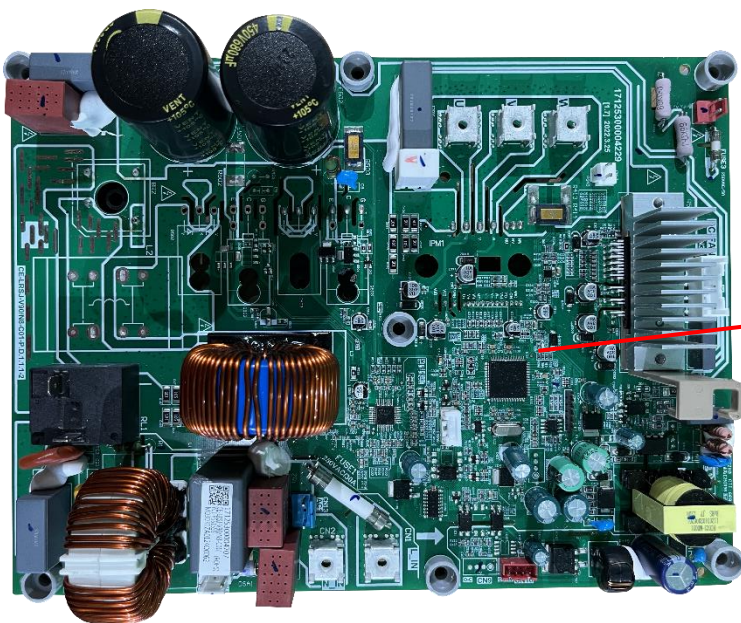



5.27.3 Principle of DC inverter

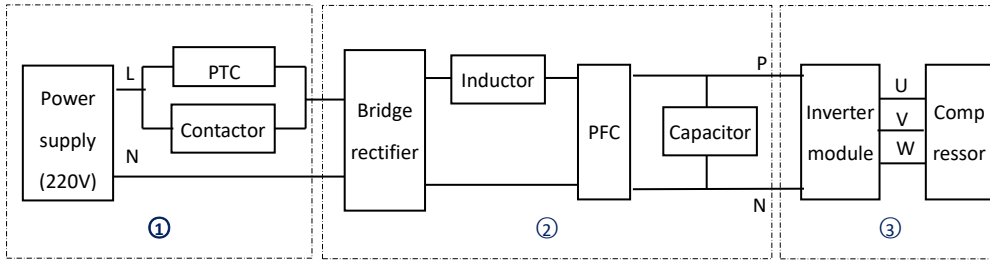

- ① Contactor is open, the current across the PTC to charge capacitor. After 5 seconds, the contactor closed.
- ② 220-240V AC power supply change to DC power supply after bridge rectifier.
- ③ The capacitor output steady power supply for inverter module P N terminals. In standby the voltage between P and N terminal on inverter module is 1.4 time of AC power supply. When the fan motor is running, the voltage is 380V DC.

5.27.4 L0/L4 troubleshooting

Situation 1: L0 or L4 error appears immediately after the compressor starts up

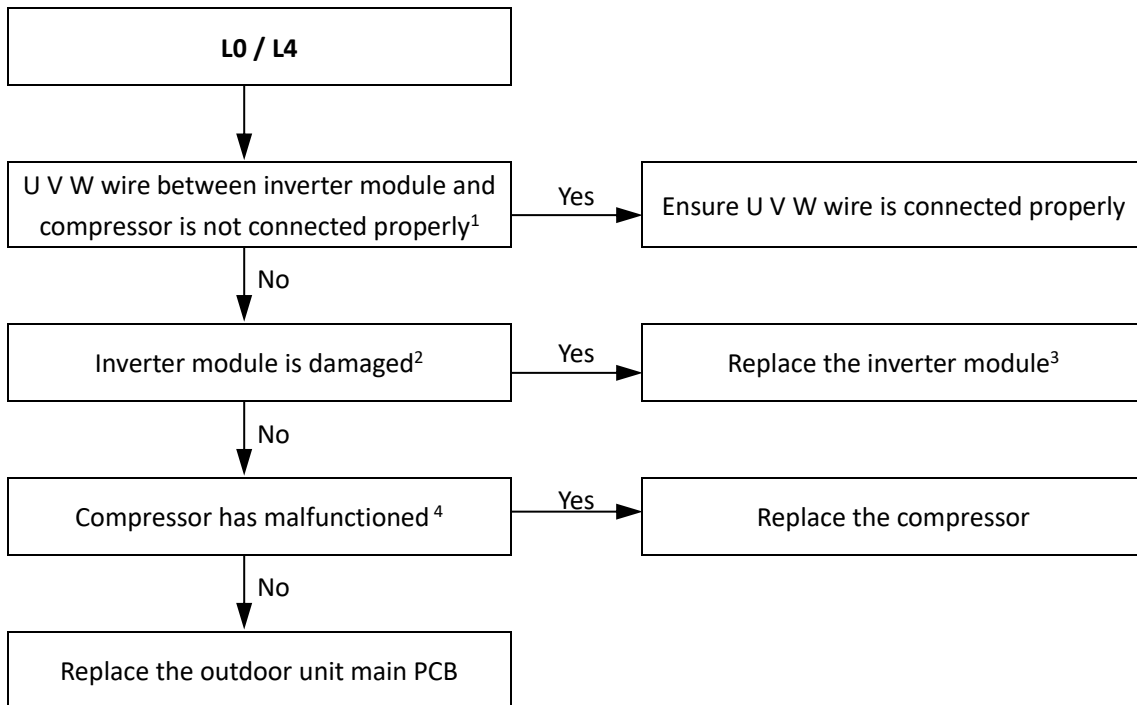

- Notes:
- 1. Connect the U V W wire from the inverter module to the correct compressor terminals, as indicated by the labels on the compressor.
  - 2. Measure the resistance between each of U, V and W and each of P and N on the inverter module. All the resistances should be infinite. If any of them are not infinite, the inverter module is damaged and should be replaced.
  - 3. When replacing an inverter module, a layer of thermally conductive silica gel should be painted on the IPM module, IGBT, diode bridge rectifier (on the reverse side of the inverter module PCB).

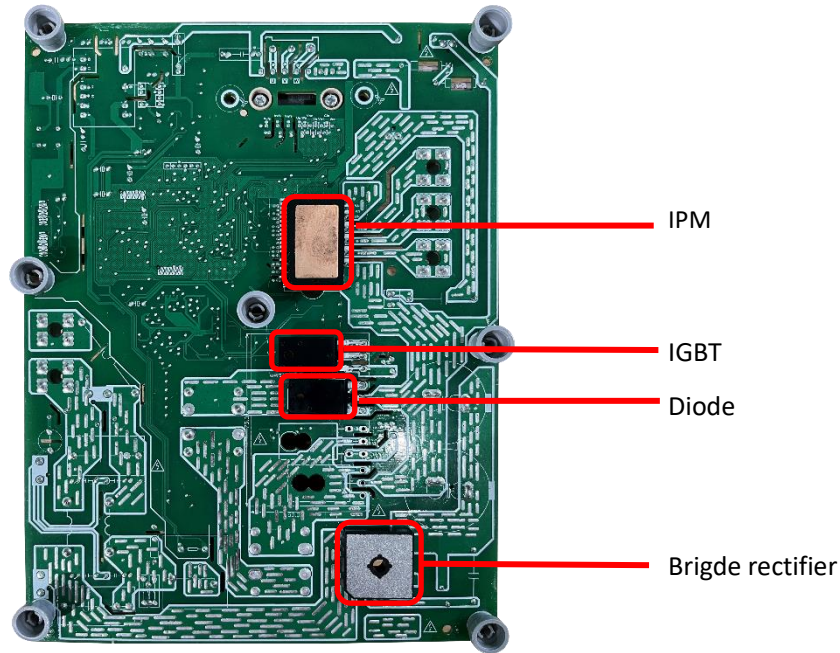

- The normal resistances of the inverter compressor are 0.7-1.5Ω among U V W and infinite between each of U V W and ground. If any of the resistances differ from these specifications, the compressor has malfunctioned.

**Situation 2: L0 or L4 error appears after the compressor has been running for a period of time and the compressor speed is over 60rps**

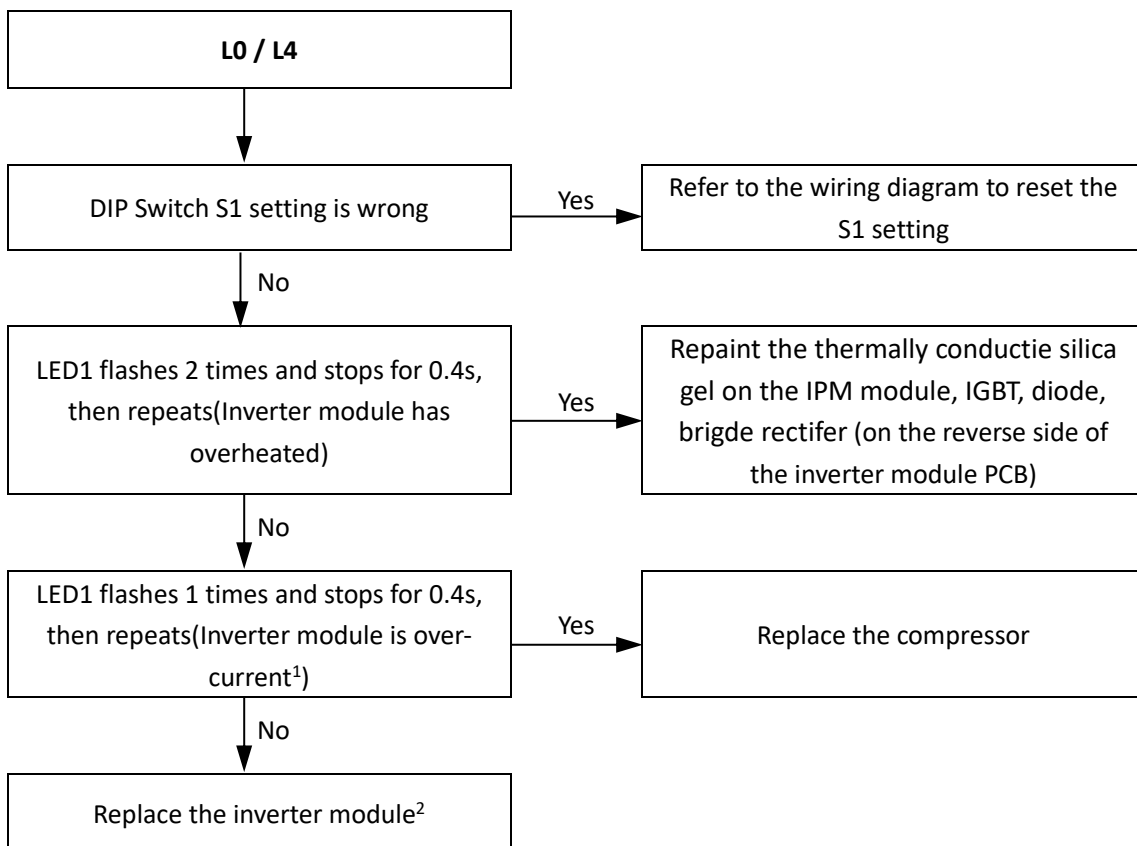

- Notes:
- Use clip-on ammeter to measure the compressor current, if the current is normal indicates the inverter module is failed, if the current is abnormal indicates the compressor is failed.
  - When replacing an inverter module, a layer of thermally conductive silica gel should be painted on the PFC and IPM modules (on the reverse side of the inverter module PCB).

Situation 3: L0 error appears occasionally/irregularly

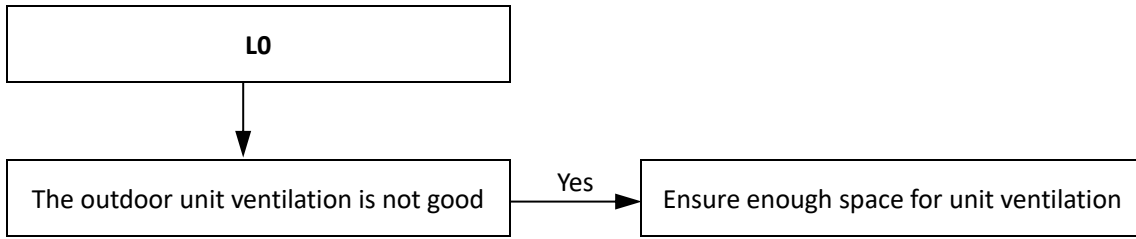

5.27.5 L1/L2 troubleshooting

The normal DC voltage between terminals P and N on inverter module is 1.4 time of AC power supply in standby , the DC voltage is 377V when the fan motor is running. If the voltage is lower than 135V, the unit displays L1. If the voltage is higher than 500V, the unit display L2.

Inverter module terminals

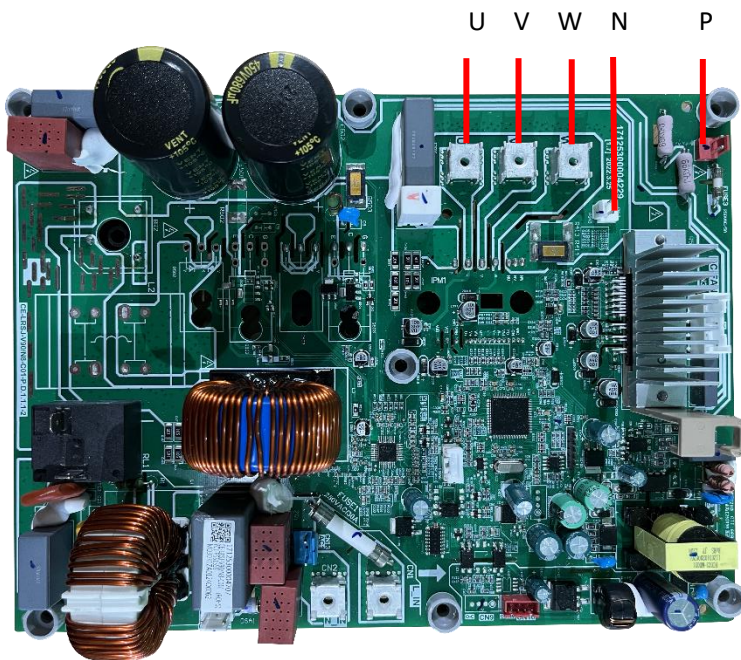

Situation 1: L1 or L2 error appears immediately after the outdoor unit is powered-on

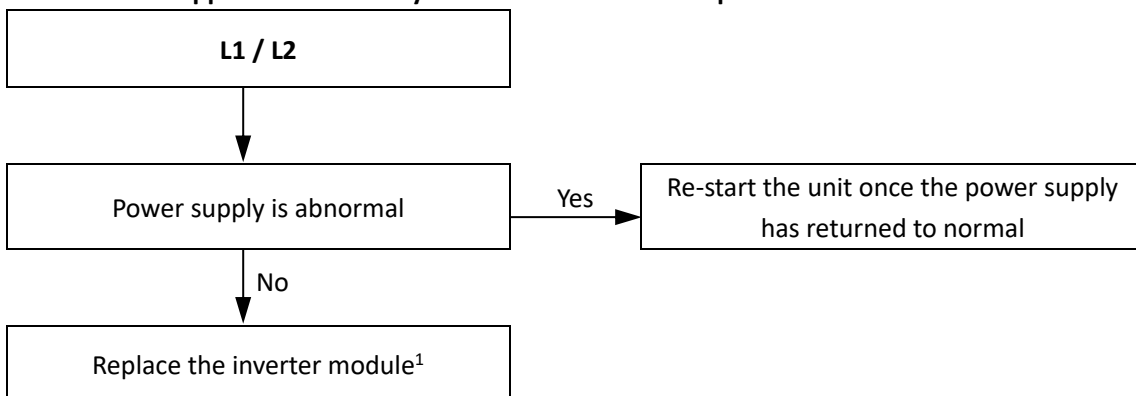

Notes:  
 1. When replacing an inverter module, a layer of thermally conductive silica gel should be painted on the IPM module, IGBT, diode, bridge rectifier (on the reverse side of the inverter module PCB).

Situation 2: L1 or L2 error appears after the compressor has been running for a period of time and the compressor speed is over 20rps

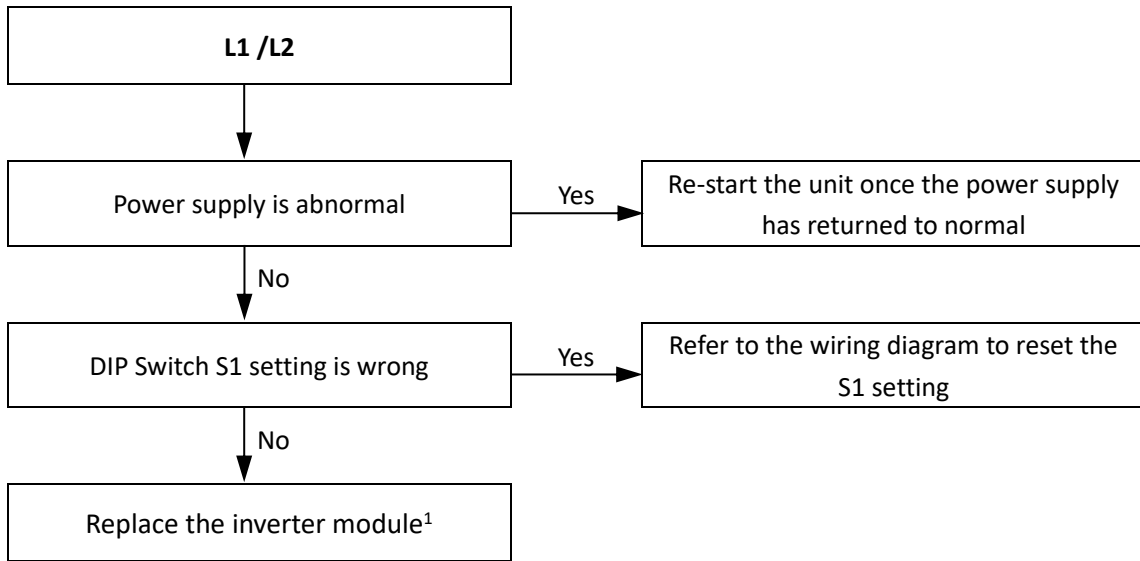

- Notes:
1. When replacing an inverter module, a layer of thermally conductive silica gel should be painted on IPM module (on the reverse side of the inverter module PCB).

5.27.6 L5/L7 troubleshooting

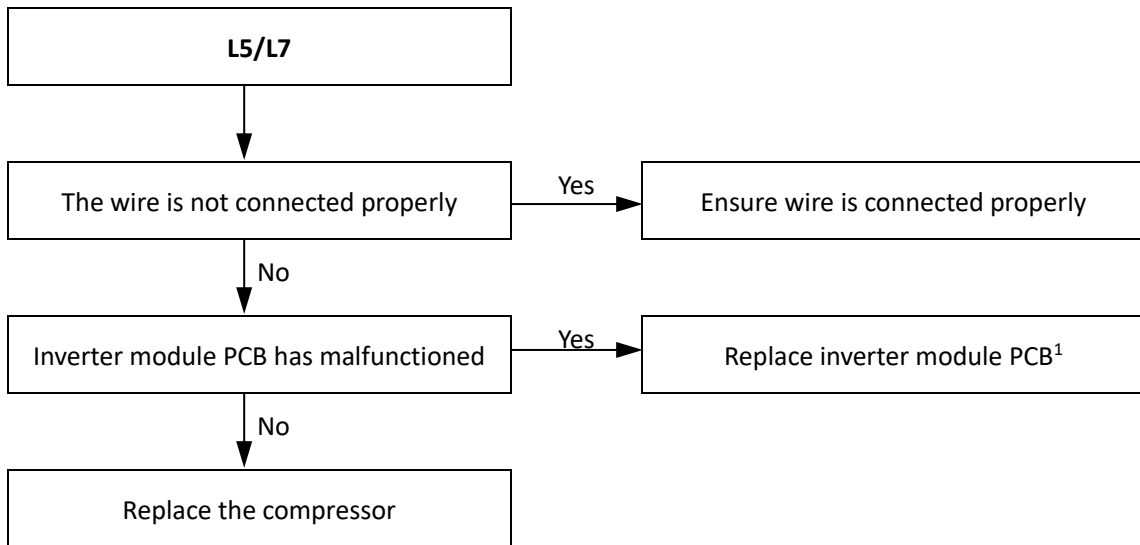

- Note:
1. When replacing an inverter module, a layer of thermally conductive silica gel should be painted on IPM module (on the reverse side of the inverter module PCB).

5.27.7 L3 troubleshooting

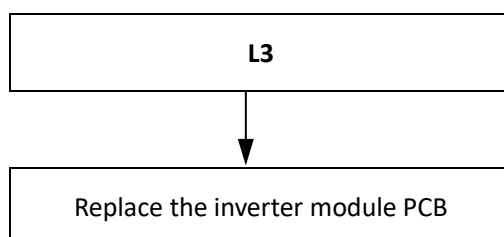

## 6 Temperature Sensor Resistance Characteristics

Outdoor ambient temperature sensor, water side heat exchanger refrigerant inlet(liquid pipe) / outlet(gas pipe) temperature sensor, air side heat exchanger refrigerant temperature sensor and suction pipe temperature sensor resistance characteristics

Temperature (°C)	Resistance (kΩ)	Temperature (°C)	Resistance (kΩ)	Temperature (°C)	Resistance (kΩ)	Temperature (°C)	Resistance (kΩ)
-25	144.266	15	16.079	55	2.841	95	0.708
-24	135.601	16	15.313	56	2.734	96	0.686
-23	127.507	17	14.588	57	2.632	97	0.666
-22	119.941	18	13.902	58	2.534	98	0.646
-21	112.867	19	13.251	59	2.44	99	0.627
-20	106.732	20	12.635	60	2.35	100	0.609
-19	100.552	21	12.05	61	2.264	101	0.591
-18	94.769	22	11.496	62	2.181	102	0.574
-17	89.353	23	10.971	63	2.102	103	0.558
-16	84.278	24	10.473	64	2.026	104	0.542
-15	79.521	25	10	65	1.953	105	0.527
-14	75.059	26	9.551	66	1.883		
-13	70.873	27	9.125	67	1.816		
-12	66.943	28	8.721	68	1.752		
-11	63.252	29	8.337	69	1.69		
-10	59.784	30	7.972	70	1.631		
-9	56.524	31	7.625	71	1.574		
-8	53.458	32	7.296	72	1.519		
-7	50.575	33	6.982	73	1.466		
-6	47.862	34	6.684	74	1.416		
-5	45.308	35	6.401	75	1.367		
-4	42.903	36	6.131	76	1.321		
-3	40.638	37	5.874	77	1.276		
-2	38.504	38	5.63	78	1.233		
-1	36.492	39	5.397	79	1.191		
0	34.596	40	5.175	80	1.151		
1	32.807	41	4.964	81	1.113		
2	31.12	42	4.763	82	1.076		
3	29.528	43	4.571	83	1.041		
4	28.026	44	4.387	84	1.007		
5	26.608	45	4.213	85	0.974		
6	25.268	46	4.046	86	0.942		
7	24.003	47	3.887	87	0.912		
8	22.808	48	3.735	88	0.883		
9	21.678	49	3.59	89	0.855		
10	20.61	50	3.451	90	0.828		
11	19.601	51	3.318	91	0.802		
12	18.646	52	3.191	92	0.777		
13	17.743	53	3.069	93	0.753		
14	16.888	54	2.952	94	0.73		

*Compressor discharge pipe temperature sensor resistance characteristics*

Temperature (°C)	Resistance (kΩ)	Temperature (°C)	Resistance (kΩ)	Temperature (°C)	Resistance (kΩ)	Temperature (°C)	Resistance (kΩ)
-20	542.7	20	68.66	60	13.59	100	3.702
-19	511.9	21	65.62	61	13.11	101	3.595
-18	483.0	22	62.73	62	12.65	102	3.492
-17	455.9	23	59.98	63	12.21	103	3.392
-16	430.5	24	57.37	64	11.79	104	3.296
-15	406.7	25	54.89	65	11.38	105	3.203
-14	384.3	26	52.53	66	10.99	106	3.113
-13	363.3	27	50.28	67	10.61	107	3.025
-12	343.6	28	48.14	68	10.25	108	2.941
-11	325.1	29	46.11	69	9.902	109	2.860
-10	307.7	30	44.17	70	9.569	110	2.781
-9	291.3	31	42.33	71	9.248	111	2.704
-8	275.9	32	40.57	72	8.940	112	2.630
-7	261.4	33	38.89	73	8.643	113	2.559
-6	247.8	34	37.30	74	8.358	114	2.489
-5	234.9	35	35.78	75	8.084	115	2.422
-4	222.8	36	34.32	76	7.820	116	2.357
-3	211.4	37	32.94	77	7.566	117	2.294
-2	200.7	38	31.62	78	7.321	118	2.233
-1	190.5	39	30.36	79	7.086	119	2.174
0	180.9	40	29.15	80	6.859	120	2.117
1	171.9	41	28.00	81	6.641	121	2.061
2	163.3	42	26.90	82	6.430	122	2.007
3	155.2	43	25.86	83	6.228	123	1.955
4	147.6	44	24.85	84	6.033	124	1.905
5	140.4	45	23.89	85	5.844	125	1.856
6	133.5	46	22.89	86	5.663	126	1.808
7	127.1	47	22.10	87	5.488	127	1.762
8	121.0	48	21.26	88	5.320	128	1.717
9	115.2	49	20.46	89	5.157	129	1.674
10	109.8	50	19.69	90	5.000	130	1.632
11	104.6	51	18.96	91	4.849		
12	99.69	52	18.26	92	4.703		
13	95.05	53	17.58	93	4.562		
14	90.66	54	16.94	94	4.426		
15	86.49	55	16.32	95	4.294		
16	82.54	56	15.73	96	4.167		
17	78.79	57	15.16	97	4.045		
18	75.24	58	14.62	98	3.927		
19	71.86	59	14.09	99	3.812		

Water side heat exchanger water inlet / outlet temperature sensor, final outlet water temperature sensor resistance characteristics

Temperature (°C)	Resistance (kΩ)	Temperature (°C)	Resistance (kΩ)	Temperature (°C)	Resistance (kΩ)	Temperature (°C)	Resistance (kΩ)
-30	867.29	10	98.227	50	17.600	90	4.4381
-29	815.80	11	93.634	51	16.943	91	.3022
-28	767.68	12	89.278	52	16.315	92	4.1711
-27	722.68	13	85.146	53	15.713	93	4.0446
-26	680.54	14	81.225	54	15.136	94	3.9225
-25	641.07	15	77.504	55	14.583	95	3.8046
-24	604.08	16	73.972	56	14.054	96	3.6908
-23	569.39	17	70.619	57	13.546	97	3.5810
-22	536.85	18	67.434	58	13.059	98	3.4748
-21	506.33	19	64.409	59	12.592	99	3.3724
-20	477.69	20	61.535	60	12.144	100	3.2734
-19	450.81	21	58.804	61	11.715	101	3.1777
-18	425.59	22	56.209	62	11.302	102	3.0853
-17	401.91	23	53.742	63	10.906	103	2.9960
-16	379.69	24	51.396	64	10.526	104	2.9096
-15	358.83	25	49.165	65	10.161	105	2.8262
-14	339.24	26	47.043	66	9.8105		
-13	320.85	27	45.025	67	9.4736		
-12	303.56	28	43.104	68	9.1498		
-11	287.33	29	41.276	69	8.8387		
-10	272.06	30	39.535	70	8.5396		
-9	257.71	31	37.878	71	8.2520		
-8	244.21	32	36.299	72	7.9755		
-7	231.51	33	34.796	73	7.7094		
-6	219.55	34	33.363	74	7.4536		
-5	208.28	35	31.977	75	7.2073		
-4	197.67	36	30.695	76	6.9704		
-3	187.66	37	29.453	77	6.7423		
-2	178.22	38	28.269	78	6.5228		
-1	168.31	39	27.139	79	6.3114		
0	160.90	40	26.061	80	6.1078		
1	152.96	41	25.031	81	5.9117		
2	145.45	42	24.048	82	5.7228		
3	138.35	43	23.109	83	5.5409		
4	131.64	44	22.212	84	5.3655		
5	125.28	45	21.355	85	5.1965		
6	119.27	46	20.536	86	5.0336		
7	113.58	47	19.752	87	4.8765		
8	108.18	48	19.003	88	4.7251		
9	103.07	49	18.286	89	4.5790		

## 7 USB function

Installers can quickly copy the wired controller parameter settings or update the program via USB disk, which save the time of on-site installation.

### Step 1

Insert the USB into port CN26 on the main PCB. If the unit is operating, then it will shut down.

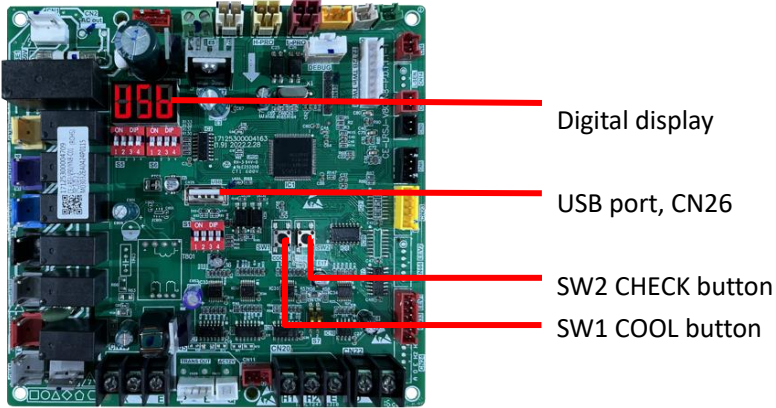

### Step 2

Press “SW2 CHECK” button to choose which function you need.

Order	Digital display	Function
1	1	Input parameters setting data
2	2	Output parameters setting data
3	3	Program update

### Step 3

Press “SW1 COOL” button to confirm.

Order	Digital display	Note
1	100	Input parameters setting data successfully
	Err	Input parameters setting data unsuccessfully
2	100	Output parameters setting data successfully
3	100	Program update successfully
	Err	Program can not be found

### Digital display

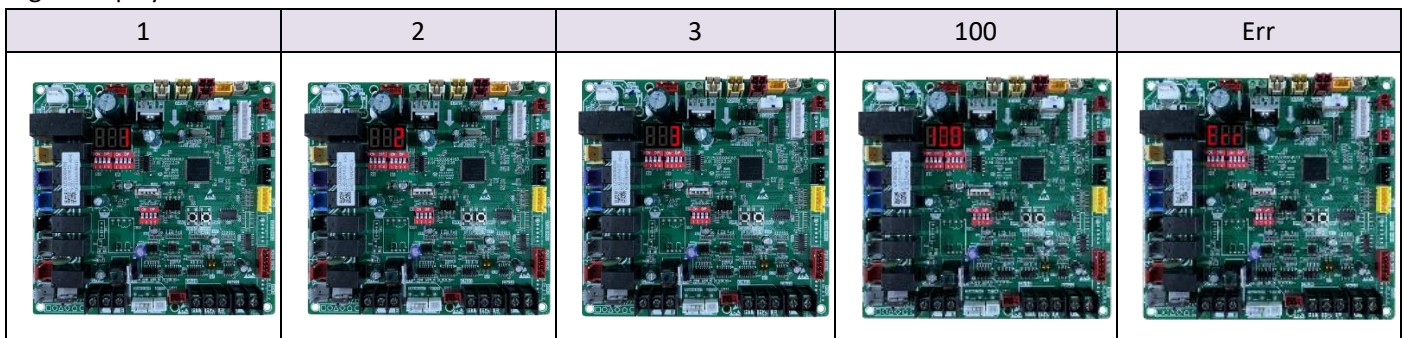



# Part 6

# Parts Replacement

1 Wired controller .....	73
2 Flow switch.....	74
3 Compressor.....	75
4 Titanium heat exchanger.....	76
5 Inverter module PCB.....	77

**Warning**

- Servicing shall only be performed as recommended by the equipment manufacturer. Maintenance and repair requiring the assistance of other skilled personnel shall be carried out under the supervision of the person competent in the use of flammable refrigerants.

**Danger**

- Before carrying out any maintenance or repairing activity, must switch off the power supply on the supply panel.
- Do not touch any live part for 10 minutes after the power supply is turned off.
- Please note that some sections of the electric component box are hot.
- When service panels are removed, live parts can be easily touched by accident.
- Never leave the unit unattended during installation or servicing when the service panel is removed.
- Forbid touch any conductive parts.
- Forbid rinse the unit. It may cause electric shock or fire.
- Forbid leave the unit unattended when service panel is removed.
- Do not touch water pipes during and immediately after operation as the pipes may be hot and could burn your hands. To avoid injury, give the piping time to return to normal temperature or be sure to wear protective gloves.
- Do not touch any switch with wet fingers. Touching a switch with wet fingers can cause electrical shock.

## 1 Wired controller

### 1.1 Remove the component

Isolate the main power supply, and prevent from accidental reconnection.

Remove the screws of the junction box(a)

Disconnect the connection wire(b)

Open the cover of the protect box and use a flat-head screwdriver to pry it from the bottom of the controller(c)

Take out the controller(d)

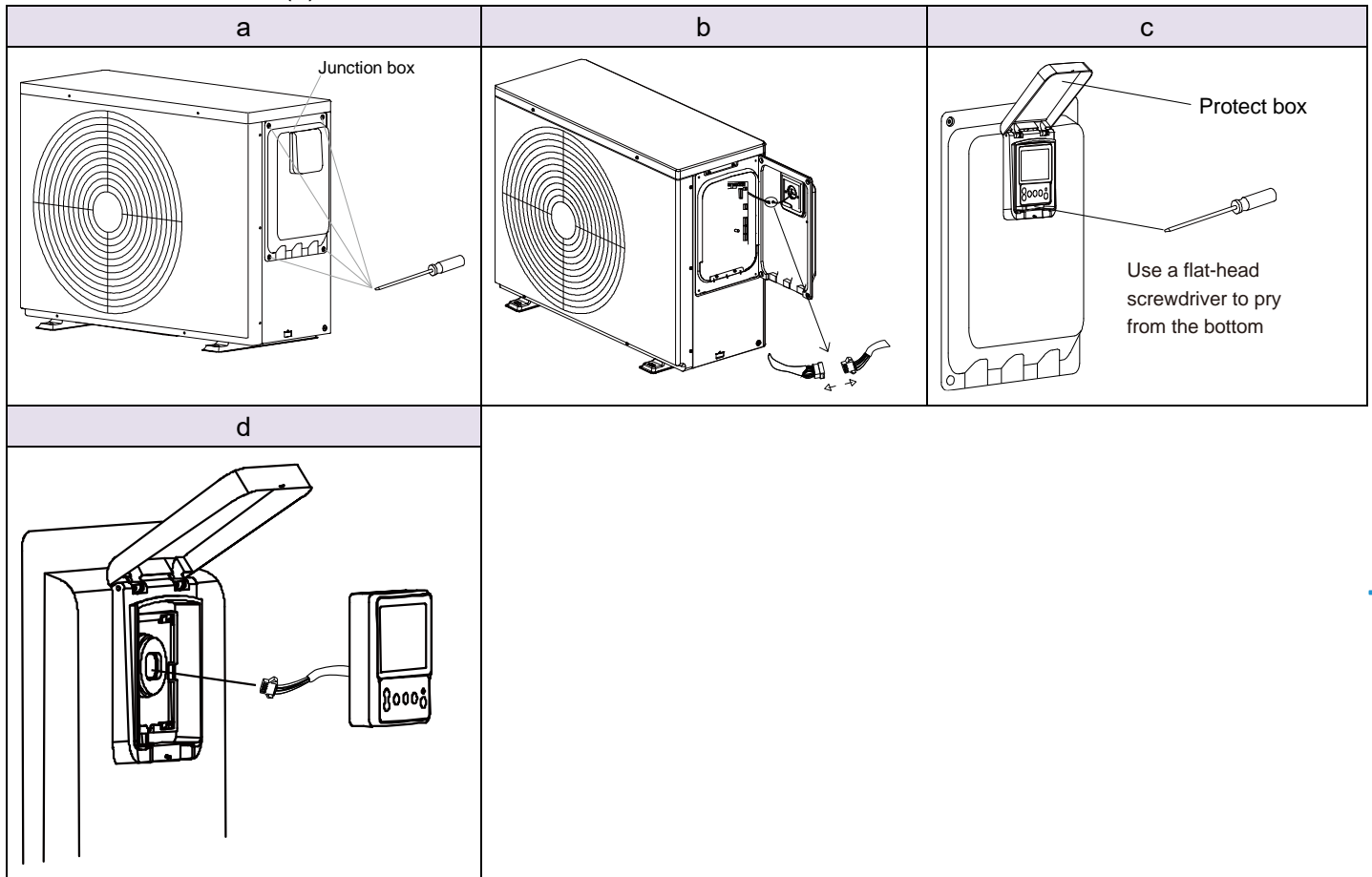

### 1.2 Install the component

Pass the connecting wire through the hole in the protecting box.

Fix the controller and connect the wire

Install the panels

## 2 Flow switch

### 2.1 Remove the component

Isolate the main power supply, and prevent from accidental reconnection.

Shut off the water supply to the unit and disconnect the water pipe joint

Remove the screws of the junction box(a)

Remove the top panel(b)

Remove the support panel(c)

Remove the flow switch which installed on the titanium heat exchanger and remove the wire terminal from main PCB(d)

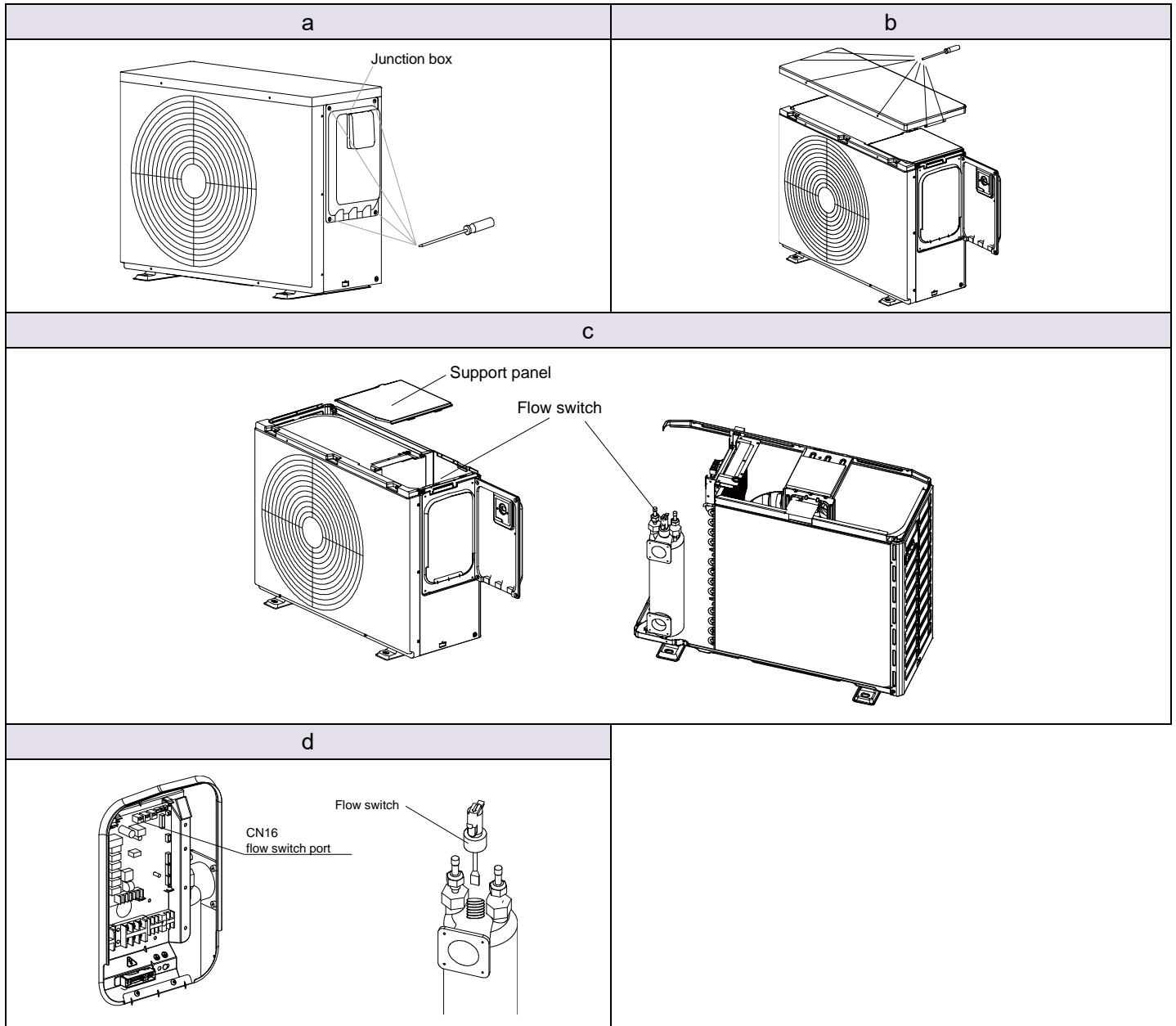

### 2.2 Install the new controller

Install a new flow switch on the titanium heat exchanger.

Connecting the wire and fix it.

Install the panels.

Connecting the water pipe joint

Install the panels

### 3 Compressor

#### 3.1 Remove the component

Isolate the main power supply, and prevent from accidental reconnection.

Remove the panels(a)

Take out all of the refrigerant and keep the needle valve/ stop-off valve opening.

Remove the compressor power cables.

Remove the retaining nut of waterproof cover and the retaining nuts on the feet(b)

Remove the connecting copper tubes using welding equipment(c)

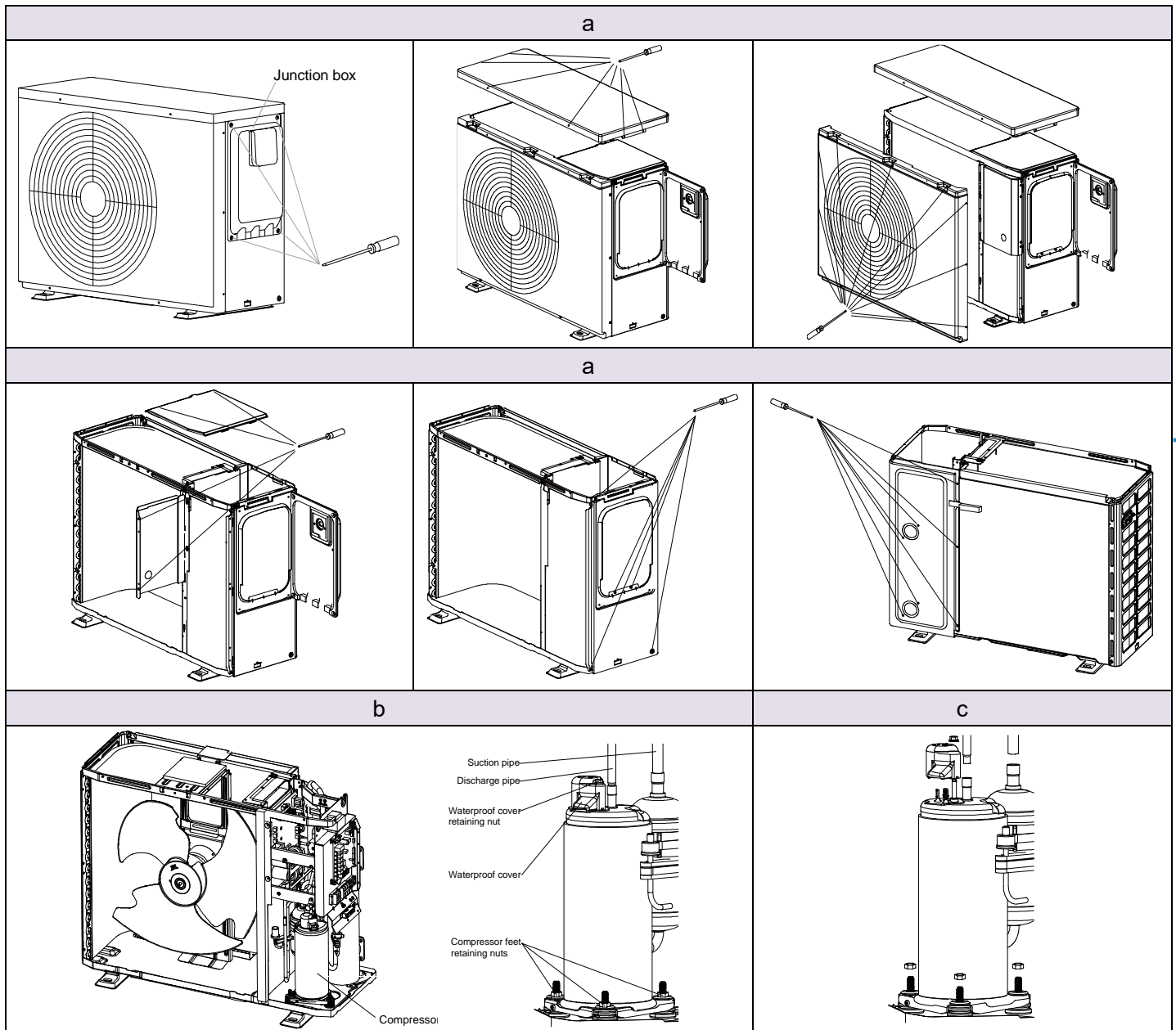

#### 3.2 Install the component

Clean the connecting cooper pipes.

Replace the new compressor in the installation position and install the retaining nuts.

Insert the connecting copper pipes and complete the welding.

Use high pressure nitrogen for leakage checking.

Vacuum the refrigerant system and recharge the refrigerant according to the nameplate.

Connect the power cable and install the waterproof cover.

Install the panels

## 4 Titanium heat exchanger

### 4.1 Remove the component

Isolate the main power supply, and prevent from accidental reconnection.

Shut off the water supply to the unit and disconnect the water pipe joint

Remove the panels(a)

Take out all of the refrigerant and keep the needle valve/ stop-off valve opening.

Remove the temperature sensors.

Remove the flow switch(Please refer to “2 Flow switch”)

Remove the bolts on the feet and the connect copper tubes using welding equipment(b)

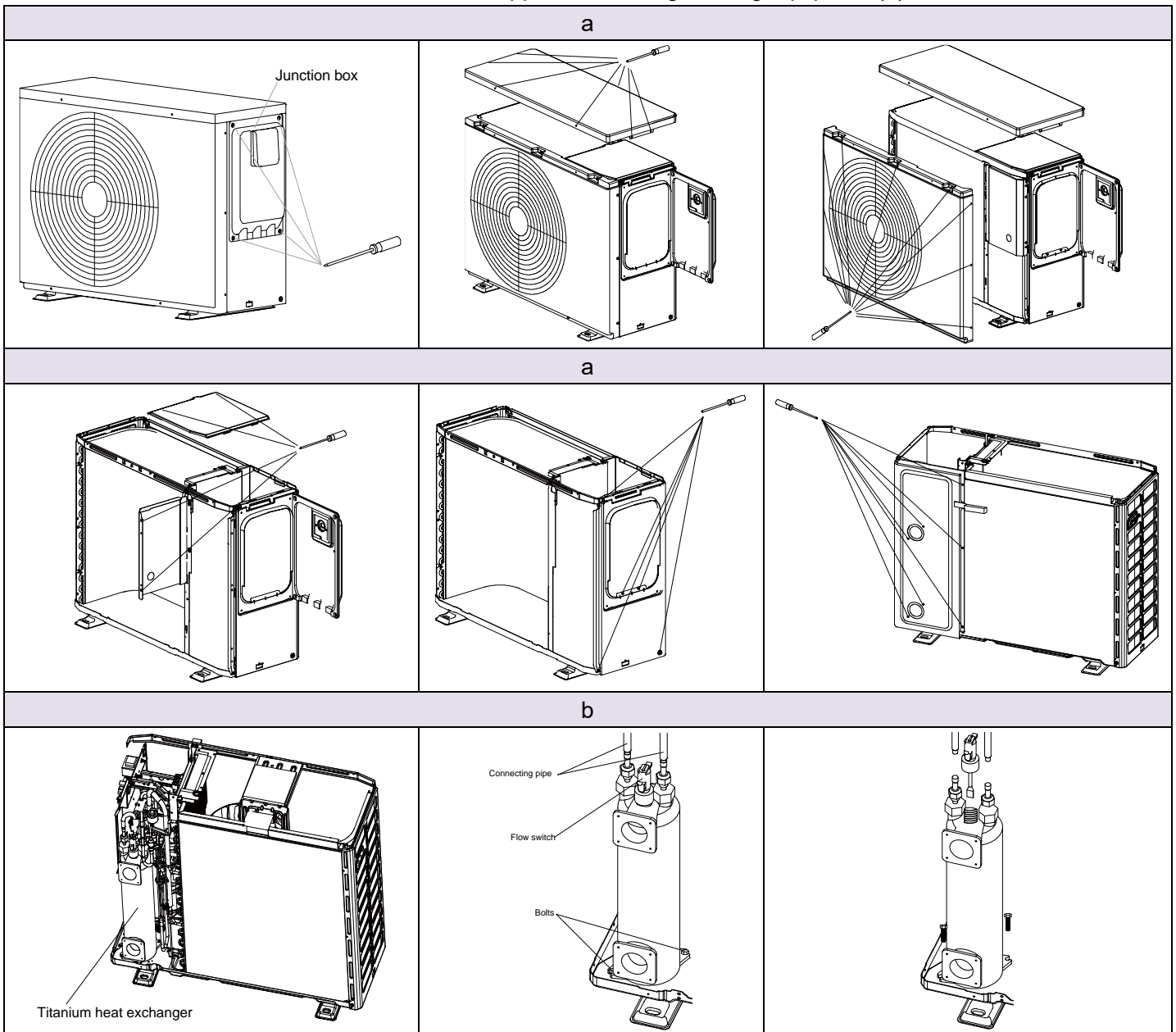

### 4.2 Install the component

Clean the connecting cooper tubes.

Replace the new titanium heat exchanger in the installation position and install the bolts.

Insert the connecting copper pipes and complete the welding.

Use high pressure nitrogen for leakage checking.

Vacuum the refrigerant system and recharge the refrigerant according to the nameplate.

Connecting the temperature sensors, water pipe joints and install the flow switch.

Install the panels

## 5 Inverter module PCB

### 5.1 Remove the component

Isolate the main power supply, and prevent from accidental reconnection.

Remove the panels(a)

Remove the connecting cables if necessary

Remove the retaining screws(b)

Pull the inverter module PCB and mounting plate out from the top(c)

Remove the retaining screws on the board.

Separate the inverter module PCB and mounting plate

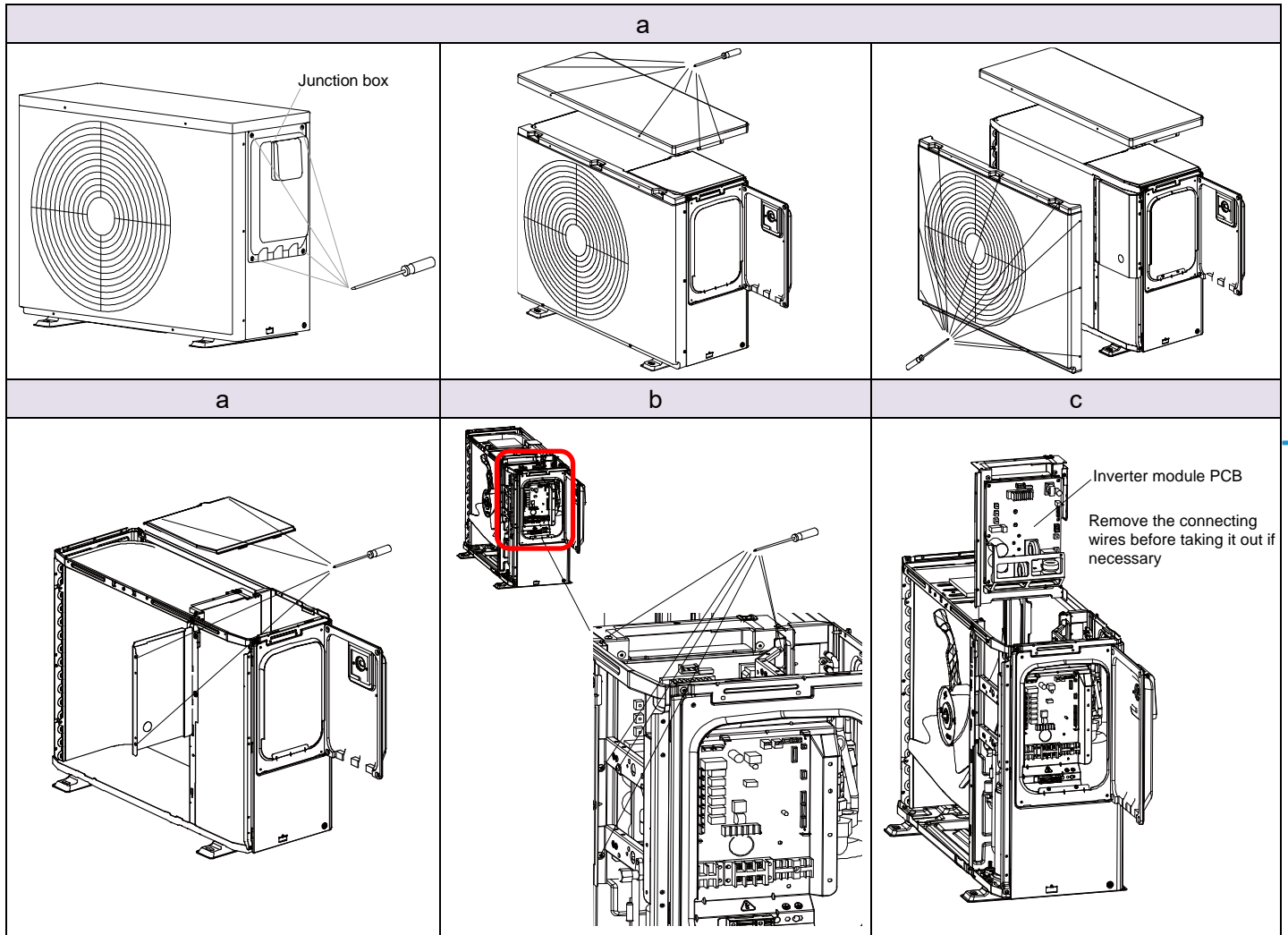

### 5.2 Install the component

Replace the new inverter module PCB in the installation position and install the screws.

Connecting all the cables.

Install the inverter module PCB and mounting plate from the top.

Install the panels.

**Midea Building Technologies Division**  
**Midea Group**

Add.: Midea Headquarters Building, 6 Midea Avenue, Shunde, Foshan, Guangdong, China

Postal code: 528311

mbt.midea.com    www.midea-group.com    tsp.midea.com

Note: Product specifications change from time to time as product improvements and developments are released and may vary from those in this document.

